

REGOLATORE DI PRESSIONE PER GAS
 GAS PRESSURE REGULATOR
 REGULATEUR DE PRESSION POUR GAZ
 REGULADOR DE PRESIÓN PARA GAS



CE II 2G - II 2D

CE 0497

MADE IN ITALY

	IT	EN	FR	ES
Range pressione di esercizio Operating pressure range Plage de pression de fonctionnement Rango de la presión de funcionamiento	Pe: 1÷2 bar			
Attacchi filettati / Threaded connections Raccords filetés / Conexiones roscadas	DN 15 - DN 20 - DN 25 - DN 32 - DN 40 - DN 50			
Attacchi filettati a 90° / Threaded connections at 90° Raccords filetés à 90° / Conexiones roscadas a 90°	DN 15 - DN 20 - DN 25 - DN 32 - DN 40 - DN 50			
	DN 25* - DN 32 - DN 40 - DN 50 - DN 65 - DN 80 - DN 100			
Attacchi flangiati / Flanged connections Raccords à brides / Conexiones embrizadas	* su richiesta con flange girevoli	* with swivel flanges on request	* sur demande avec brides tournantes	* bajo petición con bridas locas
Norma di riferimento / Reference standard Norme de référence / Patrón de referencia	EN 88-2			
In conformità a In conformity with Conforme a Conforme	Direttiva PED 2014/68/UE	PED Directive 2014/68/EU	Directive PED 2014/68/UE	Directiva PED 2014/68/UE

INDICE - INDEX - INDEX - ÍNDICE

IT

pag.

Italiano	3
English	10
Français	17
Español	24
Disegni - Drawings - Dessins - Diseños	32
Dimensioni (tabella 1a - 1b)	41
Dimensions (table 1a - 1b)	
Dimensions (tableau 1a - 1b)	
Dimensiones (tabla 1a - 1b)	
Caratteristiche molle di regolazione (tabella 3)	43
Regulation spring data (table 3)	
Caracteristiques des ressorts de réglage (tableau 3)	
Características muelles de regulación (tabla 3)	
Diagramma - Diagram - Diagramme - Diagrama Δp	44
Codifica prodotto / Product encoding / Codification du produit / Codificación del producto	46

EN

FR

ES

1.0 - GENERAL INFORMATION

This manual shows you how to safely install, operate and use the device.

The instructions for use **ALWAYS** need to be available in the facility where the device is installed.

ATTENTION: installation/maintenance needs to be carried out by qualified staff (as explained in section 1.3) by using suitable personal protective equipment (PPE).

For any information pertaining to installation/maintenance or in case of problems that cannot be solved with the instructions, contact the manufacturer by using the address and phone numbers provided on the last page.

1.1 - DESCRIPTION

Device which supplies a preset and constant “downstream” pressure value (Pa) (within the intended operating limits) when the inlet pressure (Pe) and/or the flow rate (Q) changes. The compensated obturator ensures precision when adjusting the outlet pressure (Pa) even in the case of high and sudden variations in the inlet pressure.

It is fitted with:

- a spring to adjust the outlet pressure;
- a safety membrane;
- an output pressure test nipple (with some exceptions) to control the outlet pressure (Pa). On some models the pressure test nipple is also present on the input;

It can also be supplied with a built-in filtering element (FRG/2MC models).

Available 90° connections for threaded connections from DN 15 to DN 50.

Reference standards: EN 88-2 – EN 13611. Component for industrial use on industrial sites.

1.2 - KEY OF SYMBOLS



DANGER: In the event of inobservance, this may cause damage to tangible goods.



DANGER: In the event of inobservance, this may cause damage to tangible goods, to people and/or pets.



ATTENTION: Attention is drawn to the technical details intended for qualified staff.

1.3 - QUALIFIED STAFF

These are people who:

- Are familiar with product installation, assembly, start-up and maintenance;
- Know the regulations in force in the region or country pertaining to installation and safety;
- Are trained in first aid.



1.4 - USING NON-ORIGINAL SPARE PARTS

- To perform maintenance or change parts (e.g. spring, filter element, etc.) **ONLY** manufacturer-recommended parts can be used. Using different parts not only voids the product warranty, it could compromise correct device operation.
- The manufacturer is not liable for malfunctions caused by unauthorised tampering or use of non-original parts.



1.5 - IMPROPER USE

- The product must only be used for the purpose it was built for.
- It is not allowed to use fluids other than those expressly stated.
- The technical data set forth on the rating plate must not, under any circumstances, be exceeded. The end user or installer is in charge of implementing correct systems to protect the device, which prevent the maximum pressure indicated on the rating plate from being exceeded.
- The manufacturer is not responsible for any damage caused by improper use of the device.

2.0 - TECHNICAL DATA

- Use : non-aggressive gases of the three families (dry gases)
- Ambient temperature (TS) : -15 ÷ +60 °C
- Operating pressure range (Pe) : 1 ÷ 2 bar
- Accuracy class : AC10 (P2 ± 10%)
- Closing pressure class : SG30 (P2 + 30%)
- Mechanical resistance : Group 2 (according to EN 13611)
- Rp threaded connections in line : (DN 15 - DN 20 - DN 25 - DN 32 - DN 40 - DN 50) according to EN 10226
- Rp threaded connections at 90° : (DN 15 - DN 20 - DN 25 - DN 32 - DN 40 - DN 50) according to EN 10226
- Flanged connections that can couple with PN 16 flanges : (DN 25* - DN 32 - DN 40 - DN 50 - DN 65 - DN 80 - DN 100) ISO 7005 / EN 1092-1
- NPT threaded or ANSI 150 threaded connections: on request
- Filter element (only models FRG/2MC) : filtering 50µm
- In compliance with : PED Directive 2014/68/EU - ATEX Directive 2014/34/EU

* DN 25 with swivel flanges on request.

2.1 - MODEL IDENTIFICATION

- RG/2MC:** Pressure regulator for gas without filter - (connections in line)
- FRG/2MC:** Pressure regulator for gas with built-in filter - (connections in line)
- RG/2MCR:** Pressure regulator for gas without filter - (connections at 90° see figure 2 and 4)
- FRG/2MCR:** Pressure regulator for gas with built-in filter - (connections at 90° see figure 2 and 4)

3.0 - COMMISSIONING THE DEVICE



3.1 - OPERATIONS PRIOR TO INSTALLATION

- It is necessary to close the gas upstream of the device prior to installation;
- Make sure that the line pressure **DOES NOT EXCEED** the maximum pressure declared on the product label;
- Protective caps (if any) must be removed prior to installation;
- The pipes and inside of the device must be clear of any foreign bodies;
- **IMPORTANT:** to avoid possible pumping and/or disturbances in the gas flow, a straight pipe section equal to at least 5 DN must be installed (downstream of the regulator).
- **IMPORTANT:** install manual gas closing devices (e.g. ball valves) upstream and downstream of the regulator to protect it from any pipe leak test;

If the device is threaded:

- make sure that the pipe thread is not too long, to prevent damaging the body of the device when screwing it on;

If the device is flanged:

- make sure the inlet and outlet counter-flanges are perfectly coaxial and parallel in order to prevent unnecessary mechanical stress to the body. Also calculate the space to insert the seal gasket;
- With regard to tightening operations, equip yourself with one or two calibrated torque wrenches or other controlled locking tools;
- The safety regulations on handling loads in force in the country of installation must be complied with. If the device to be installed exceeds the weight allowed, suitable mechanical equipment and adequate slings must be used. Necessary precautions must be taken during the handling phases so as not to damage/ruin the external surface of the device.
- If the regulator is not fitted with a filter, it is advisable to install an adequate filter upstream;
- With outdoor installation, it is advisable to install a protective roof to prevent rain from oxidising or damaging parts of the device.



- According to the plant geometry, check the risk of an explosive mixture arising inside the piping;
- If the regulator is installed near other devices or as part of an assembly, compatibility between the regulator and these devices must be evaluated beforehand;
- Provide a protection against impacts or accidental contacts if the device is accessible to unqualified personnel.



3.2 - INSTALLATION (see example in 3.4)

Threaded devices:

- Assemble the device by screwing it, with the due seals, onto the plant with pipes and/or fittings whose threads are consistent with the connection being attached.
- Do not use the neck of the top cover (4) as a lever to help you screw it on, only use the specific tool;
- The arrow, shown on the body (11) of the device, needs to be pointing towards the application;

Flanged devices:

- Assemble the device by flanging it, with the due seals, onto the plant with pipes whose flanges are consistent with the connection being attached. The gaskets must be free from defects and must be centred between the flanges;
- If, after installing the gaskets, there is still an excessive space in between, do not try to reduce the said gap by excessively tightening the bolts of the device;
- The arrow, shown on the body (11) of the device, needs to be pointing towards the application;
- Insert the relative washers inside the bolts in order to prevent damage to the flanges during tightening;
- When tightening, be careful not to “pinch” or damage the gasket;
- Tighten the nuts or bolts gradually, in a “cross” pattern (see the example below);
- Tighten them, first by 30%, then by 60% and finally 100% of the maximum torque (see the table below according to EN 13611);

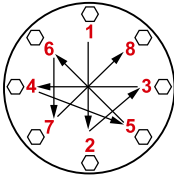

Diameter	DN 25	DN 32	DN 40	DN 50	DN 65	DN 80	DN 100
Max. torque (N.m)	30	50	50	50	50	50	80

- Tighten each nut and bolt again clockwise at least once, until the maximum torque has been achieved uniformly;

Common procedures (threaded and flanged devices):

- The regulator is normally positioned before the utility. Primarily evaluate the possibility of installing the regulator as shown in the installation example in 3.4, namely in an optimal position pos. **a** (see figures below);
- Should this not be possible, the following factors must be considered:
 1. if installed as shown in pos. **b** the maximum Pa value declared on the rating plate could be less by a few mbar.
NOTE: for versions with 90° connections, it is recommended to install a filter after the regulator that protects it from debris that could enter from downstream from above (due to gravity);
 2. if installed as shown in pos. **c** the life span of the product could be shorter than the duration that could be obtained if installed in the optimal position **a**;
 3. if installed as shown in pos. **d**, besides that indicated for pos. **c** it is recommended to install a filter after the regulator that protects it from debris that could enter from downstream from above (due to gravity);

Connections in line

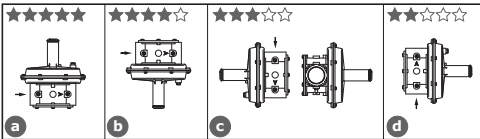

90° connections (closed line output)

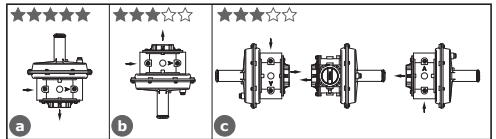

- During installation, avoid debris or metal residues from getting into the device;
- To guarantee mechanical tension-free assembly, we recommend using compensating joints, which also adjust to the pipe's thermal expansion;
- If the device is to be installed in a ramp, it is the installer's responsibility to provide suitable supports or correctly sized supports, to properly hold and secure the assembly. Never, for any reason whatsoever, leave the weight of the ramp only on the connections (threaded or flanged) of the individual devices;
- In any case, after the installation check the tightness of the system, avoiding to subject the membrane of the regulator (therefore, the downstream pipe section) to a pressure higher than 300 mbar;

3.3 - INSTALLATION IN PLACES WHERE THERE IS THE RISK OF EXPLOSION (DIRECTIVE 2014/34/EU)

The regulator complies with Directive 2014/34/EU as a device of group II, category 2G and as device of group II, category 2D; consequently, it is suited for installation in zones 1 and 21 (besides zones 2 and 22) as classified in Annex I of Directive 99/92/EC.

The regulator is not suited for use in zones 0 and 20 as defined in the aforementioned Directive 99/92/EC.

To determine the qualification and size of the danger zones, please refer to standard IEC EN 60079-10-1.

If the device is installed and serviced in full compliance with all the conditions and technical instructions provided in this document, it does not pose a source of specific hazards: in particular, under normal operating conditions, the regulator emits a flammable substance into the atmosphere **ONLY** if both the working membrane (**9**) and the safety membrane (**7**) malfunction: in which case (and only if so), the regulator constitutes a source of emission of explosive atmosphere of continuous degree and, as such, it can generate danger zones 0, as defined in Directive 99/92/EC.

In particularly critical installation conditions (unattended areas, poor maintenance or poor ventilation) and especially if there are potential sources of ignition and/or hazardous equipment near the regulator in regular operation, as they may generate electric arcs or sparks, a preliminary assessment of the compatibility between the regulator and such equipment must be carried out.

In any case, every useful precaution must be adopted so as to prevent the regulator from generating zones 0: for example, annually verify regular operation, possibility of changing the degree of emission of the source or intervening on the external explosive substance discharge. For this purpose the threaded hole of the top cover (**4**) can be connected to the outside (using appropriate fittings and pipes) by removing the dust cap (**6**).

3.4 - GENERIC EXAMPLE OF AN INSTALLATION

1. M16/RM N.C. Manual reset solenoid valve
2. SM jerk ON/OFF valve
3. FM gas filter
4. OPSO series MVB/1 MAX shut off valve
5. **RG/2MC pressure regulator**
6. MVS/1 relief valve
7. Pressure gauge and relative button
8. Vent valve
9. Ball valve
10. Gas detector
11. SM remote jerk ON/OFF valve lever control
12. Expansion joint/anti-vibration mount

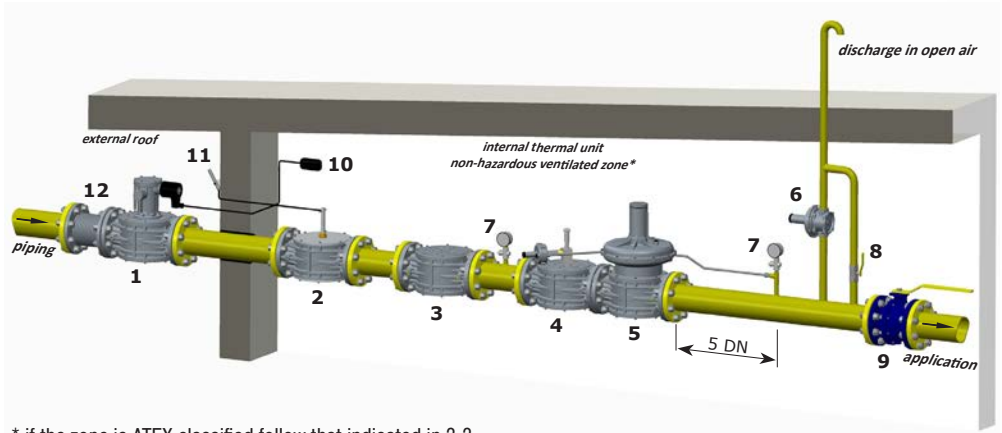

* if the zone is ATEX classified follow that indicated in 3.3



4.0 - FIRST START-UP

Before commissioning, verify that:

- all of the instructions on the rating plate, including the direction of flow, are observed;
- the holes of the dust cap (6) are not clogged.



- **IMPORTANT:** The leak test of the piping must be performed while avoiding to subject the membrane of the regulator (therefore, the downstream pipe section) to a pressure higher than 300 mbar. Use special manual gas closing devices to prevent damaging the regulator;

- The pressurisation manoeuvre of the equipment must be carried out very slowly so as to avoid possible damage.

NOTE: under no circumstances should a blind cap be placed instead of the dust cap (6) as the regulator may not work;

- Open the downstream vent valve partially;
- Slowly open the upstream shut-off devices (e.g. solenoid valves, OPSO shut-off valve, etc.);
- Wait until the downstream pressure stabilises at the calibration value Pa of the spring (indicated on the rating plate);
- Close the vent valve;
- Check the tightness of all the system gaskets and check the internal/external tightness of the regulator;
- Open the downstream shut-off valve very slowly;
- Check the operation of the regulator.



4.1 - RECOMMENDED PERIODIC CHECKS

- Use a suitable calibration tool to ensure the bolts are tightened as indicated in 3.2;
- Check the tightness of the flanged/threaded connections on the system;
- Check the tightness and operation of the regulator;

It is the responsibility of the final user or installer to define the frequency of these checks based on the severity of the service conditions.



4.2 - ADJUSTING THE OUTLET PRESSURE

Before starting the system, make sure that the spring supplied with the regulator is suitable for the desired adjustment pressure. The outlet pressure Pa (unless specifically requested) is factory set with the top cover (4) positioned as shown in 3.2 a and with the adjustment screw (2) set approximately at the minimum calibration value.

If the regulator is installed in different positions, check and reset the outlet pressure Pa.

Adjust the outlet pressure as follows:

- Unscrew the cap (1);
- Unscrew the adjustment screw (2) and set it to the minimum calibration allowed (threaded end of the top cover (4));
- Start the system or make sure there is a minimum flow downstream of the regulator;
- To increase the pressure calibration downstream of the regulator, tighten the adjustment screw (2) to the desired value. Perform the reading with a calibrated pressure gauge, installed downstream of the regulator to at least 5 DN (see example in 3.4);
- Screw the cap (1) back on and if necessary, seal it in that position using the appropriate seal holes (if present);
- Use pressure outlets (13) on the device only for zero flow or very low flow measurements.



4.3 - REPLACING THE SPRING



The step must be carried out without gas inside the regulator.

Replace the spring as follows:

- Unscrew and remove the cap (1) from the top cover (4);
- Completely loosen and take out the adjustment screw (2);
- Remove the spring washer (26);
- Remove the spring (3) from the top cover (4) and replace it with the new spring;
- Place the washer (26) on the new spring once again;
- Tighten the adjustment screw (2) and after starting the system as shown in 4.0, set the outlet pressure to the desired value as shown in 4.2;
- Screw the cap (1) back on and if necessary, seal it in that position using the appropriate seal holes (if present);



5.0 - MAINTENANCE



• Before carrying out any dismantling operation on the device, make sure that there is no pressurised gas inside.

Check the condition of the filtering element (21) as follows

- Loosen the fastening screws (17) and very carefully remove the bottom cover (16) from the body (11);
- Extract the filter element and check its conditions. Blow it and clean it and, if necessary, replace it (see figures "a" and "b" below for the positioning);
- Check the conditions of the sealing O-Ring of the bottom cover (16) and replace if necessary;
- Make sure the sealing O-Ring (18) of the bottom cover (16) is inside the relevant groove before putting it back on;
- Reassemble the bottom cover (16) and secure it in its original position, being very careful not to "pinch" or damage the O-ring during tightening.

IMPORTANT:

1. for DN 15 ÷ DN 50 connections make sure that the centre pin (10) is centred in the guide of the bottom cover (16);
 2. for DN 65 - DN 80 - DN 100 connections pay attention to the Teflon split ring (14): when reassembling the bottom cover (16) it must be placed inside the specific guide (as shown in figure 6);
- Tighten the screws gradually, following a "cross" pattern, until the torque (tolerance -15%) indicated in table 2 on page 41 is reached. Use a calibrated torque wrench to do this.
 - Check the body/cover seal;

NOTE: for internal inspections, it is recommended to:

- Also check the obturator's integrity and, if necessary, replace the rubber seal (15);
- Replace the seals before reassembling.
- It is recommended to contact the Technical Department to check or replace the membranes.

fig. a: DN 15 ÷ DN 50 cover without bottom cover

Filter element guides

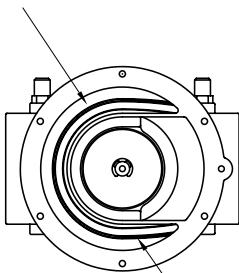

The filter element must be placed inside these guides

fig. b: DN 65 ÷ DN 100 cover without bottom cover

Filter element guides

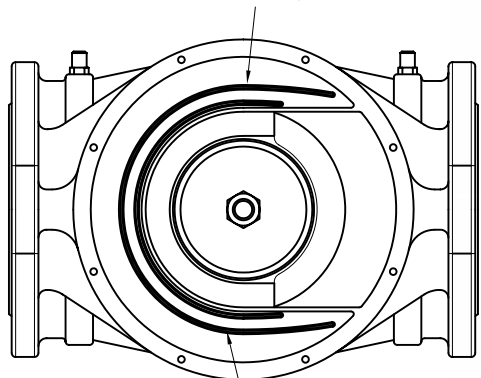

The filter element must be placed inside these guides

6.0 - TRANSPORT, STORAGE AND DISPOSAL

- During transport the material needs to be handled with care, avoiding any impact or vibrations to the device;
- If the product has any surface treatments (ex. painting, cataphoresis, etc) it must not be damaged during transport;
- The transport and storage temperatures must observe the values provided on the rating plate;
- If the device is not installed immediately after delivery it must be correctly placed in storage in a dry and clean place;
- In humid facilities, it is necessary to use driers or heating to avoid condensation.
- At the end of its service life, the product is to be disposed of in compliance with the legislation in force in the country where this operation is performed.

7.0 - WARRANTY

The warranty conditions agreed with the manufacturer at the time of the supply apply.

For damage caused by:



- Improper use of the device;
- Failure to observe the requirements described herein;
- Failure to observe the regulations pertaining to installation;
- Tampering, modification and use of non-original spare parts;

are not covered by the rights of the warranty or compensation for damage.

The warranty also excludes maintenance work, other manufacturers's assembling units, making changes to the device and natural wear.

8.0 - RATING PLATE DATA

The rating plate data (see example provided here) includes the following:

- Manufacturer's name/logo and address (possible distributor name/logo)
- Mod.: = device name/model followed by the connection diameter
- Gr. 2 = Mechanical resistance group 2 in accordance with EN 13611
- EN 88-2 = Product reference regulation
- PS=Pe = Maximum pressure or inlet pressure range at which product operation is guaranteed
- Pa = Outlet pressure range
- AC = Accuracy class of the regulator
- TS = Temperature range within which product operation is guaranteed
-  = In compliance with ATEX Dir. followed by the protection mode
-  = In compliance with PED directive followed by Notified Body No.
- year = Year of manufacture
- Lot = Product serial number (see explanation below)
 - U1823 = Lot issued in year 2018 in the 23rd week
 - 14216 = progressive job order number for the indicated year
 - 00001 = progressive number referring to the quantity of the lot

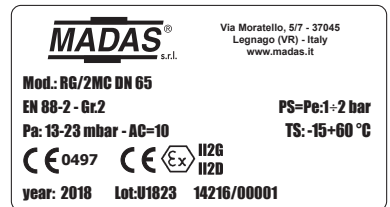
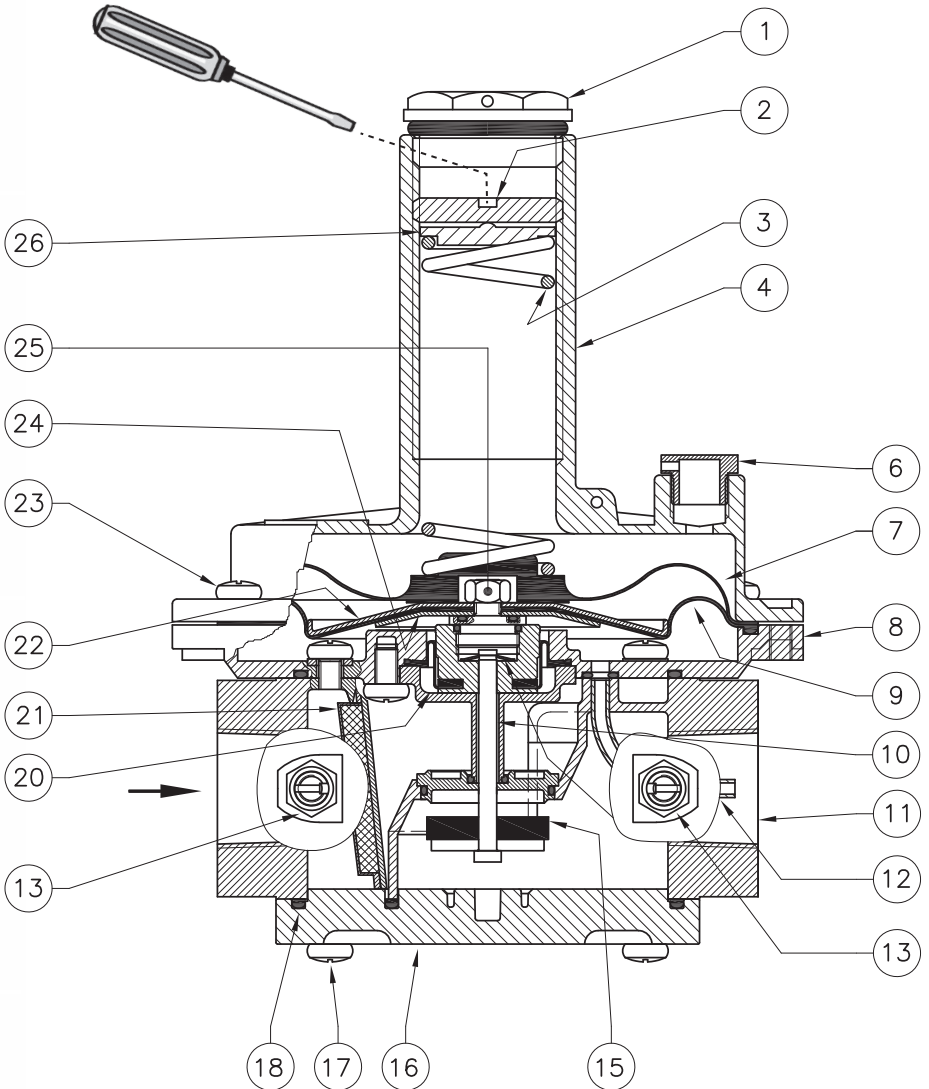

fig. 1

Attacchi filettati in linea / Threaded connections in line / Raccords filetés en ligne / Conexiones roscadas en línea
DN 15 - DN 20 - DN 25



IT

EN

FR

ES

fig. 2

Attacchi filettati a 90° / Threaded connections at 90° / Raccords filetés à 90° / Conexiones roscadas a 90°
DN 15 - DN 20 - DN 25

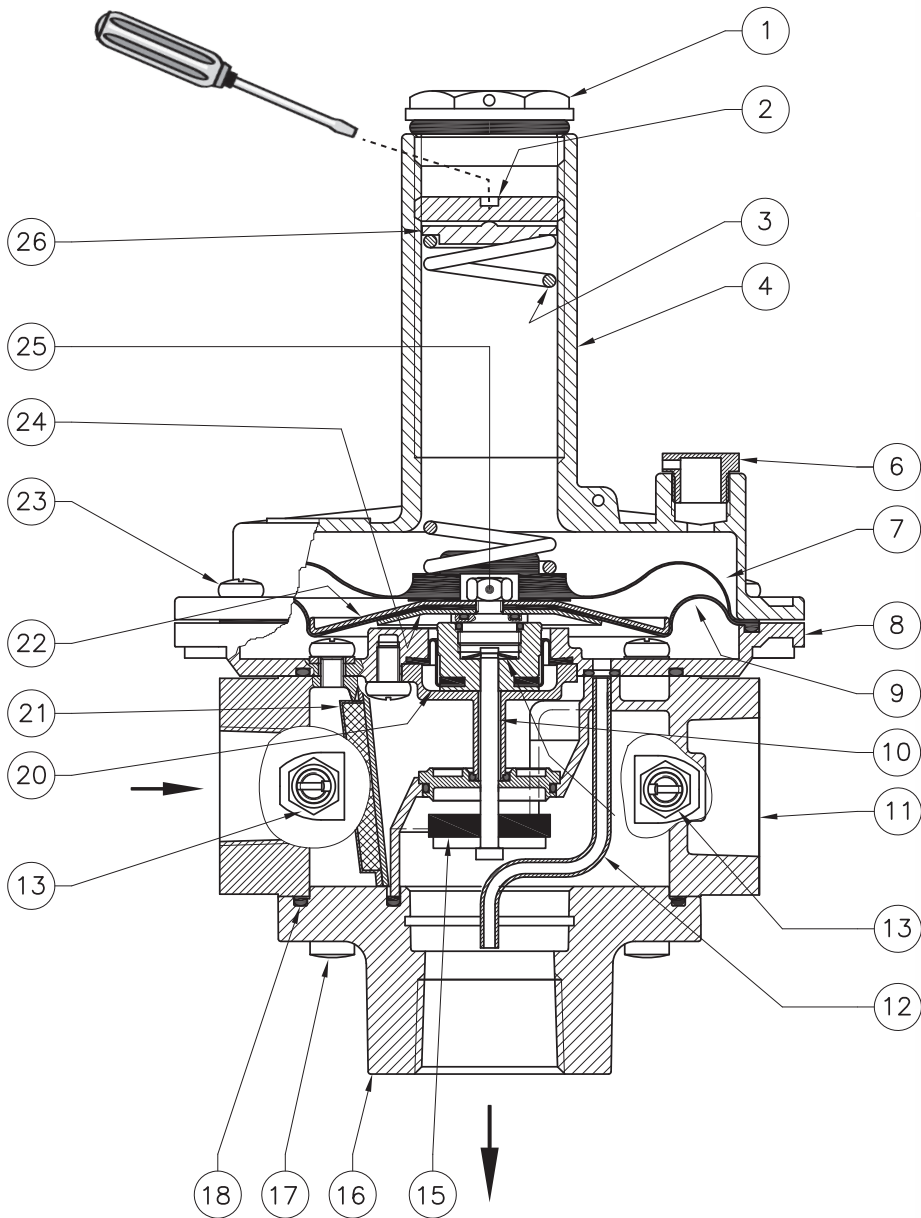

IT

EN

FR

ES

fig. 3

Attacchi filettati in linea / Threaded connections in line / Raccords filetés en ligne / Conexiones roscadas en línea
DN 32 - DN 40 - DN 50

IT

EN

FR

ES

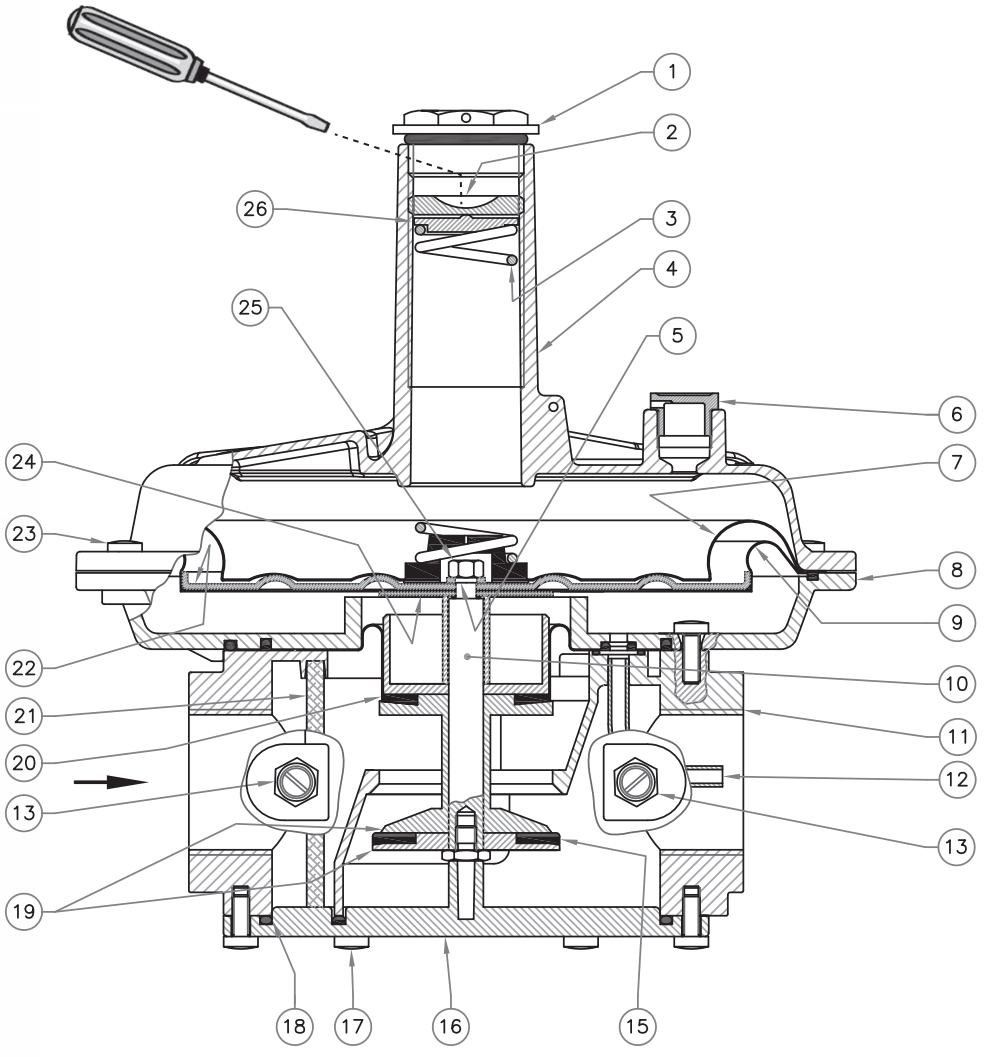
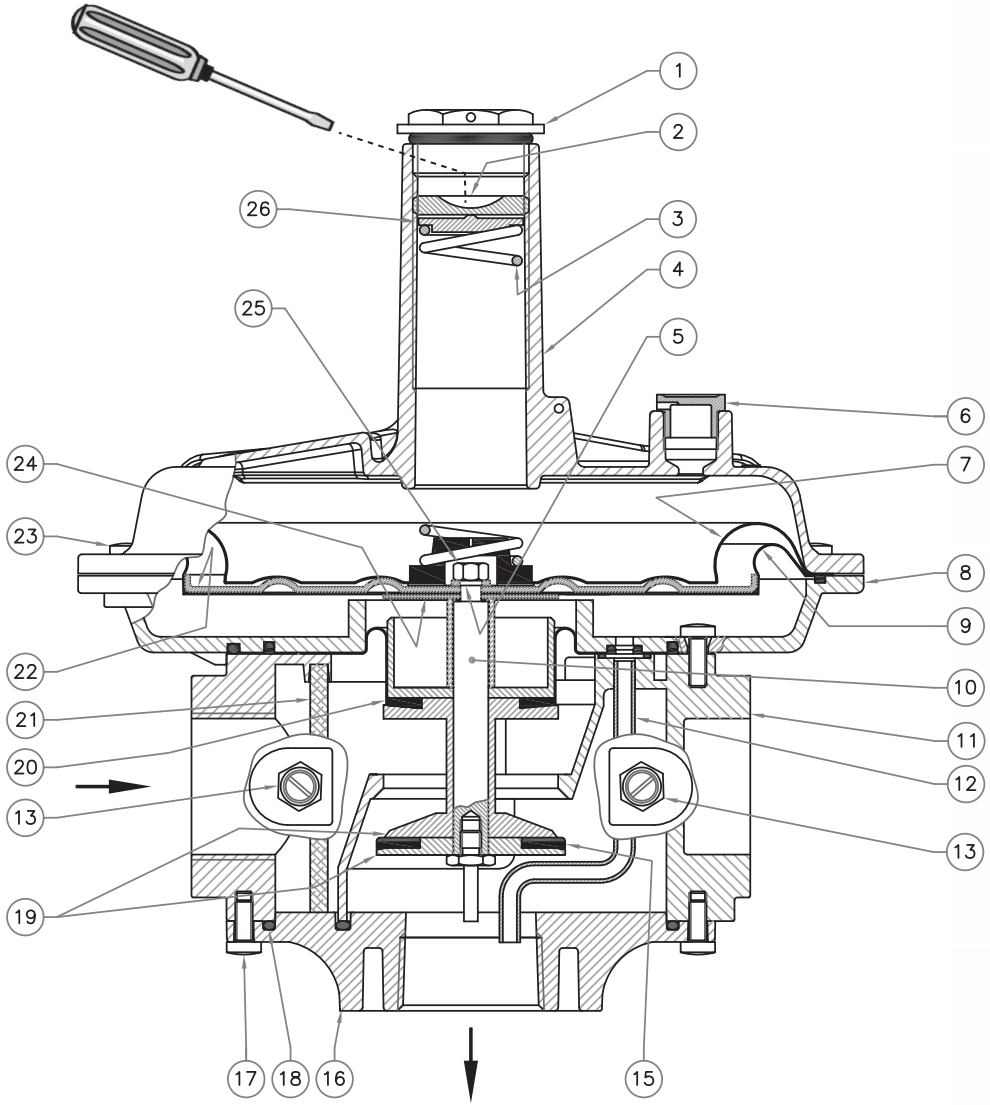

fig. 4

Attacchi filettati a 90° / Threaded connections at 90° / Raccords filetés à 90° / Conexiones roscadas a 90°
DN 32 - DN 40 - DN 50



IT

EN

FR

ES

fig. 5

Attacchi flangiati / Flanged connections / Raccords à bride / Conexiones embridadas

DN 32 - DN 40 - DN 50

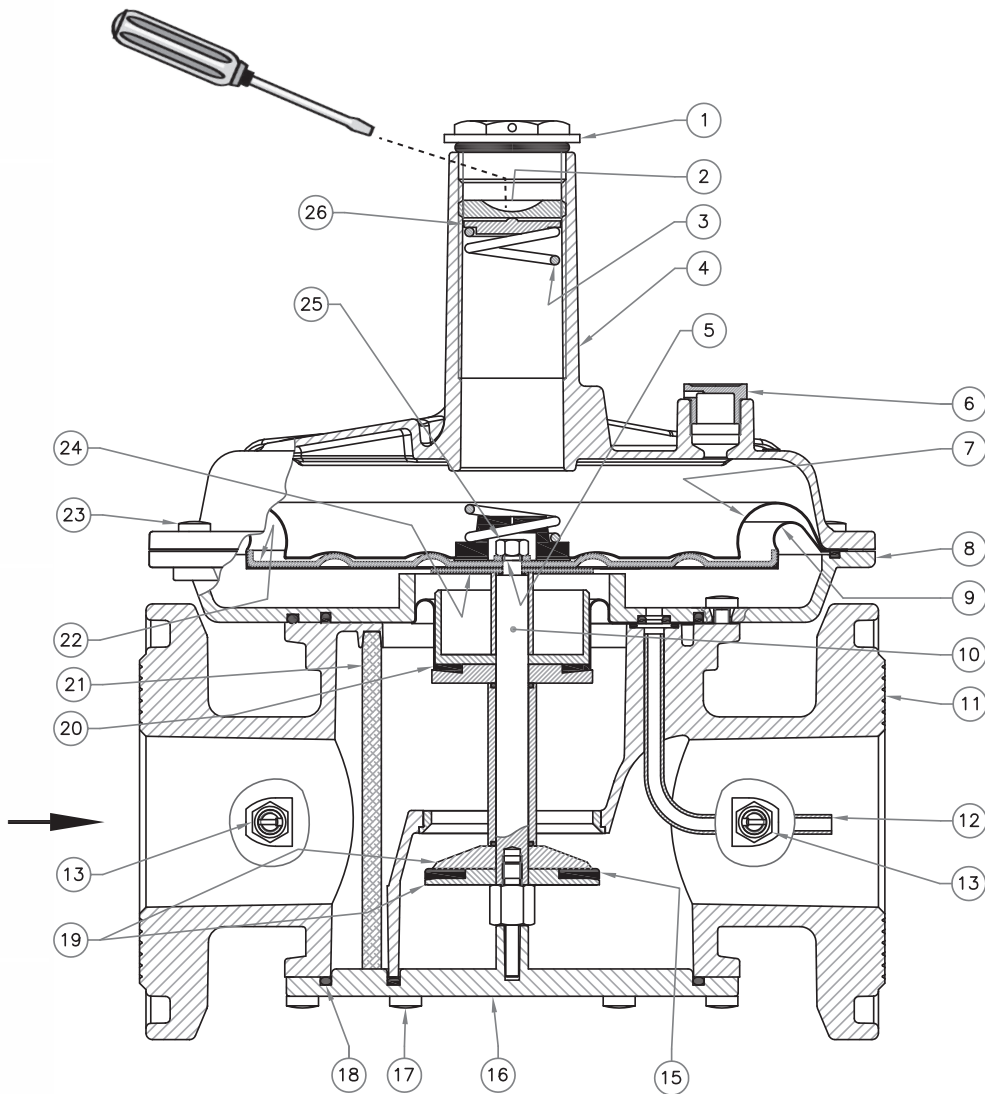

IT

EN

FR

ES

fig. 6

Attacchi flangiati / Flanged connections / Raccords à bride / Conexiones embridadas
DN 65 - DN 80 - DN 100

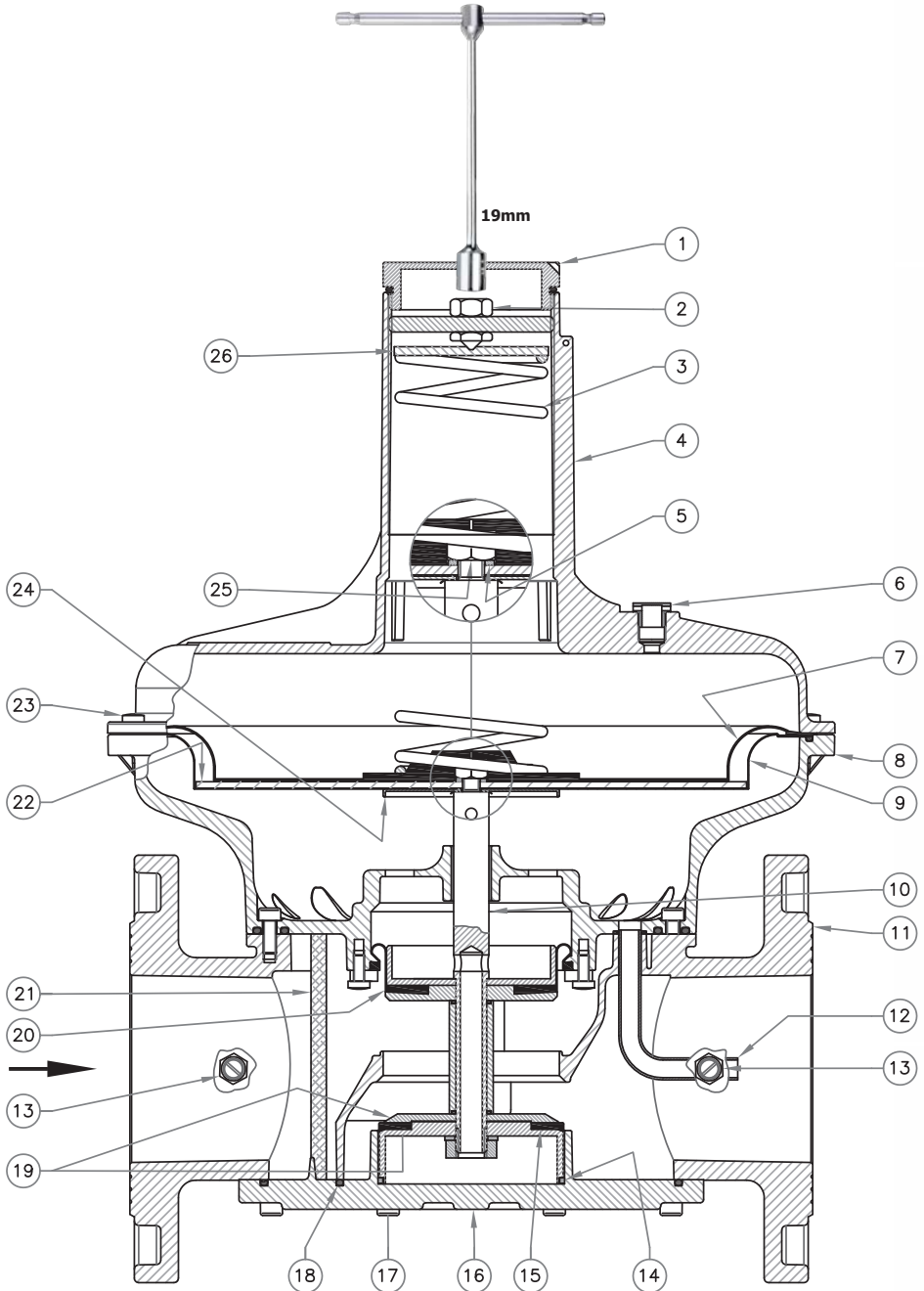

IT

EN

FR

ES

fig. 7

DN 65 - DN 80 - DN 100 - (P2: 200÷600 mbar)

versione pilotata / piloted version / version pilotée / versión pilotada

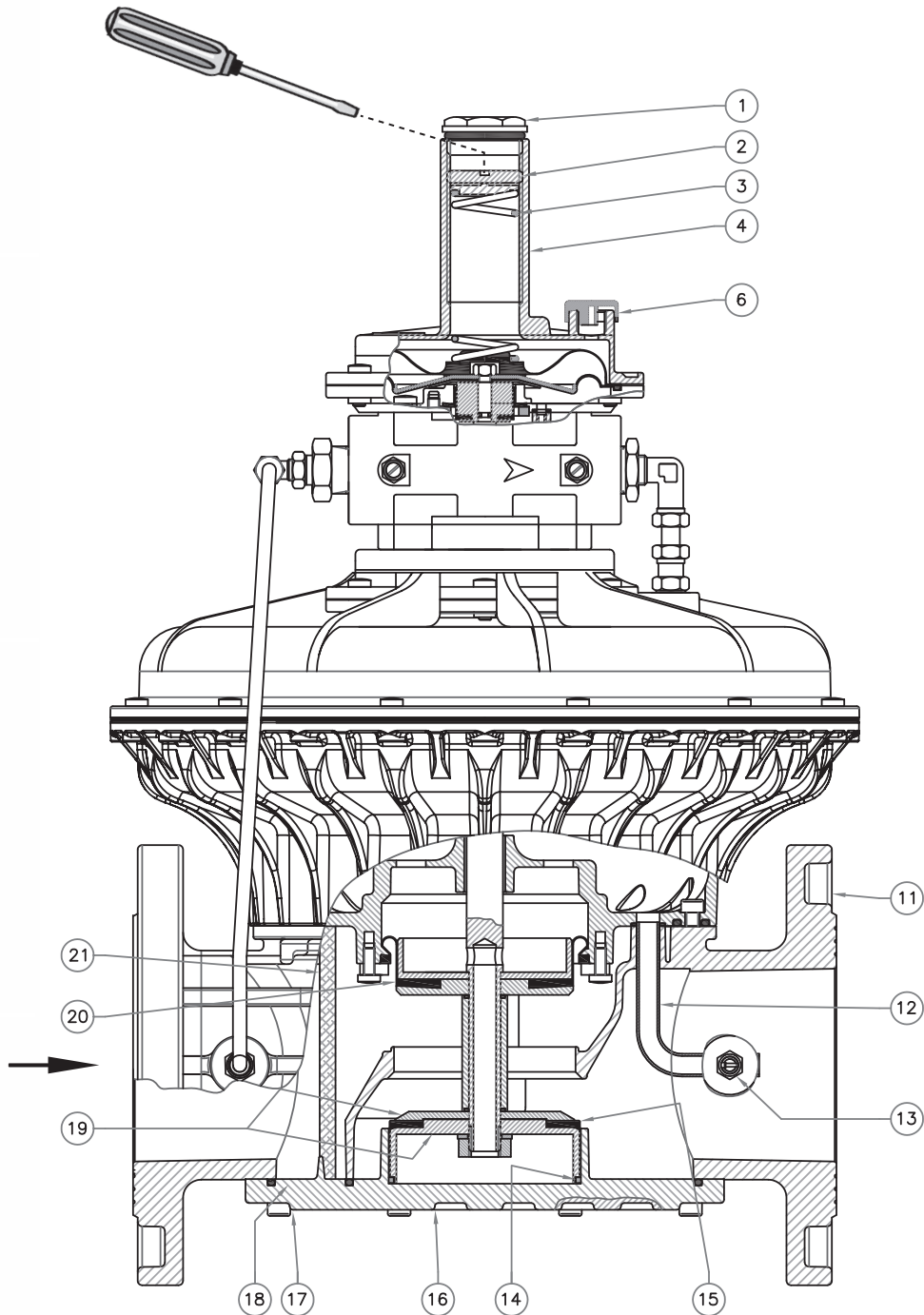

IT

EN

FR

ES

IT

fig. 1, 2, 3, 4, 5, 6 e 7

1. Tappo di chiusura
2. Vite di regolazione Pa
3. Molla di taratura
4. Coperchio superiore
5. Rondella dentellata
(eccetto DN 15-20-25)
6. Tappo antipolvere
7. Membrana di sicurezza
8. Flangia
9. Membrana di funzionamento
10. Perno centrale
(su DN 15-20-25 perno otturatore)
11. Corpo
12. Tubo sensore
13. Presa di pressione
14. Anello di teflon (solo su DN 65-80-100)
15. Rondella di tenuta
16. Coperchio inferiore
17. Viti di fissaggio coperchio inferiore
18. O-Ring di tenuta coperchio inferiore
19. Otturatore
20. Membrana di compensazione
21. Organo filtrante
22. Disco superiore per membrana
23. Viti di fissaggio coperchio superiore
24. Disco inferiore per membrana
25. Dado di fissaggio membrana/dischi
26. Rondella per molla

EN

fig. 1, 2, 3, 4, 5, 6 and 7

1. Closing cap
2. Pa adjustment screw
3. Calibration spring
4. Top cover
5. Toothed washer
(except DN 15-20-25)
6. Dust cap
7. Safety membrane
8. Flange
9. Working membrane
10. Centre pin
(on DN 15-20-25 obturator pin)
11. Body
12. Sensor tube
13. Pressure test nipple
14. Teflon ring (only on DN 65-80-100)
15. Sealing washer
16. Bottom cover
17. Bottom cover clamping screws
18. Bottom cover sealing O-Ring
19. Obturator
20. Compensation membrane
21. Filter element
22. Top disk for membrane
23. Top cover clamping screws
24. Bottom disk for membrane
25. Membrane/disc fixing nut
26. Spring washer

IT

EN

FR

ES

FR

fig. 1, 2, 3, 4, 5, 6 et 7

1. Bouchon de fermeture
2. Vis de réglage de Pa
3. Ressort d'étalonnage
4. Couvreclre supérieur
5. Rondelle dentée
(sauf DN 15-20-25)
6. Bouchon anti-poussière
7. Membrane de sécurité
8. Bride
9. Membrane de fonctionnement
10. Pivo central
(sur DN 15-20-25 pivo obturateur)
11. Corps
12. Tube capteur
13. Prise de pression
14. Bague en téflon (uniquement sur DN 65-80-100)
15. Rondelle d'étanchéité
16. Couvreclre inférieur
17. Vis de fixation du couvreclre inférieur
18. Joint torique d'étanchéité du couvreclre inférieur
19. Obturateur
20. Membrane de compensation
21. Organe filtrant
22. Disque supérieur pour membrane
23. Vis de fixation du couvreclre supérieur
24. Disque inférieur pour membrane
25. Écrou de fixation pour membrane/disques
26. Rondelle pour ressort

ES

fig. 1, 2, 3, 4, 5, 6 y 7

1. Tapón de cierre
2. Tornillo de regulación Pa
3. Muelle de calibración
4. Tapa superior
5. Arandela dentada
(excepto DN 15-20-25)
6. Tapón anti-polvo
7. Membrana de seguridad
8. Brida
9. Membrana de funcionamiento
10. Perno central
(en DN 15-20-25 perno obturador)
11. Cuerpo
12. Tubo sensor
13. Toma de presión
14. Anillo de teflón (solo en DN 65-80-100)
15. Arandela de estanqueidad
16. Tapa inferior
17. Tornillos de fijación de la tapa inferior
18. Junta tórica de estanqueidad de la tapa inferior
19. Obturador
20. Membrana de compensación
21. Cartucho filtrante
22. Disco superior para membrana
23. Tornillos de fijación de la tapa superior
24. Disco inferior para membrana
25. Tuerca de fijación membrana/discos
26. Arandela para muelle

Tabella 1a - Table 1a - Tableau 1a - Tabla 1a

Dimensioni di ingombro in mm - Overall dimensions in mm - Mesures d'encombrement en mm - Dimensiones en mm

Attacchi filettati in linea Threaded connections in line Raccords filetés en ligne Conexiones roscadas en línea	Attacchi filettati a 90° Threaded connections at 90° Raccords filetés à 90° Conexiones roscadas a 90°	Attacchi flangiati Flanged connections Raccords à bride Conexiones embridadas	fori holes trous orificios	A	B=(D+E)	C	D	E
Rp DN 15 - Rp DN 20 Rp DN 25	-		-	120	194	140	38,5	155,5
-	Rp DN 15 - Rp DN 20 Rp DN 25		-	120	213	140	63,5	155,5
Rp DN 32 - Rp DN 40 Rp DN 50	-		-	160	242	225	48,5	193,5
-	Rp DN 32 - Rp DN 40 Rp DN 50		-	160	257	225	63,5	193,5
		PN 16 - ANSI 150 DN 25	4	191	212	140	57,5	154,5
		PN 16 DN 32 FL	4	230	285	225	67,5	217,5
		PN 16 - ANSI 150 DN 40 FL - DN 50 FL	4	230	285	225	67,5	217,5
		PN 16 - ANSI 150 DN 65	4	290	456	330	90	366
		PN 16 DN 80	8	310	463	330	97	366
		ANSI 150 DN 80	4	290	456	330	90	366
		PN 16 - ANSI 150 DN 100	8	350	502	330	106	396

*Connessioni in linea
Connections in line
Connexions en ligne
Conexiones en línea*

*Connessioni a 90° (uscita in linea chiusa)
90° connections (closed line output)
Connexions à 90° (sortie en ligne fermée)
Conexiones a 90° (salida en línea cerrada)*

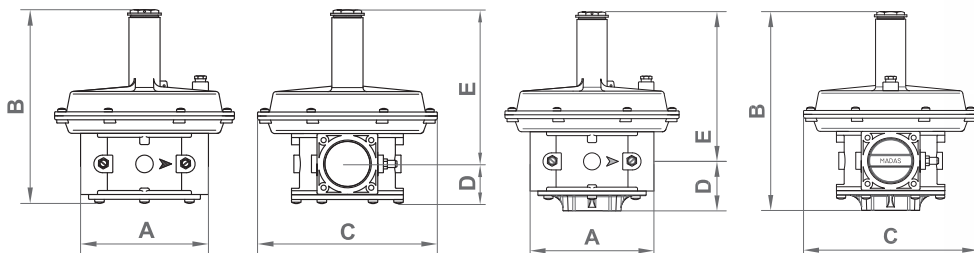

Le dimensioni sono indicative, non vincolanti - The dimensions are provided as a guideline, they are not binding
Les dimensions sont indicatives, non contraignantes - Las dimensiones son indicativas, no vinculantes

Tabella 1b - Table 1b - Tableau 1b - Tabla 1b

Dimensioni di ingombro in mm - Overall dimensions in mm - Mesures d'encombrement en mm - Dimensiones en mm

Attacchi flangiati Flanged connections Raccords à bride Conexiones embridadas	fori holes trous orificios	A	B=(D+E)	C	D	E
PN 16 - ANSI 150 DN 65	4	290	508	330	90	418
PN 16 DN 80	8	310	515	330	97	418
ANSI 150 DN 80	4	290	508	330	90	418
PN 16 - ANSI 150 DN 100	8	350	551	330	106	445

Versione pilotata (fig. 7) - Piloted version (fig. 7) - Version pilotée (fig. 7) - Versión pilotada (fig. 7)

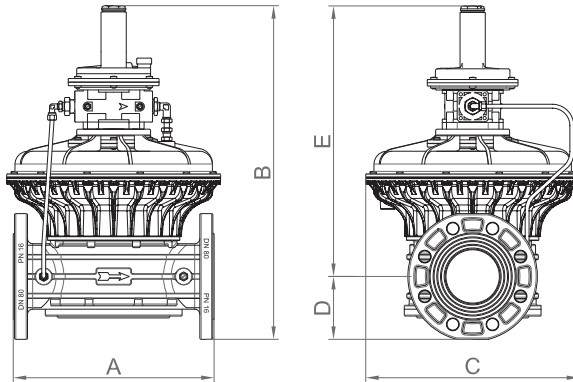

Le dimensioni sono indicative, non vincolanti - The dimensions are provided as a guideline, they are not binding
 Les dimensions sont indicatives, non contraignantes - Las dimensiones son indicativas, no vinculantes

Tabella 2 - Table 2 - Tableau 2 - Tabla 2

	Vite / Screw / Vis / Tornillo	M5	M6
Coppia max (N.m) Max. torque (N.m) Couple max. (N.m) Par máximo (N.m)	Zincato / Galvanised / Galvanisé / Galvanizado	6	10
	Acc. INOX / Stainless Steel / Ac. INOX / Acero INOX	4,5	7,5

Tabella 3 - Table 3 - Tableau 3 - Tabla 3

Caratteristiche molle di regolazione / Regulation spring data
 Caracteristiques des ressorts de reglage / Características muelles de regulación

Codice molla Spring code Code ressort Código muelle	dimensioni in mm (d x De x Lo x it) dimensions in mm (d x De x Lo x it) mesures en mm (d x De x Lo x it) dimensiones en mm (d x De x Lo x it)	Attacchi Connections Raccords Conexiones	Taratura (mbar) Setting (mbar) Tarage (mbar) Tarado (mbar)
MO-0400	1,5x29x100x12	DN 15 - DN 20 - DN 25	9 ÷ 22
MO-0500	1,6x29x115x12		20 ÷ 40
MO-0825	2,2x29x100x12		40 ÷ 110
MO-0900	2,5x29x140x18,5		110 ÷ 150
MO-0970	2,5x29x155x16		150 ÷ 200
MO-1305	3,5x29,8x98x11,5		200 ÷ 600
MO-0825	2,2x29x100x12	DN 32 - DN 40 - DN 50	12 ÷ 35
MO-0850	2,2x29x140x18		20 ÷ 36
MO-0900	2,5x29x140x18,5		30 ÷ 50
MO-0970	2,5x29x155x16		40 ÷ 60
MO-1000	3,2x29x123x15,5		60 ÷ 95
MO-1370	3,5x29x125x14		90 ÷ 190
MO-2550 *	4X29X98X8	DN 65 - DN 80	190 ÷ 400
MO-1070	4x66,5x155x16		7 ÷ 18
MO-1100	4,5x70x200x15,5		13 ÷ 27
MO-1200	5x70x205x9,5		22 ÷ 50
MO-1400\ZN	6x70x214x10,5		50 ÷ 130
MO-1400\ZN + MO-1800\ZN	6x70x214x10,5 + 5,5x54,5x195x12,5		110 ÷ 200
MO-1305 #	3,5x29,8x98x11,5	DN 100	200 ÷ 600
MO-1070	4x66,5x155x16		7 ÷ 16
MO-1100	4,5x70x200x15,5		15 ÷ 27
MO-1200	5x70x205x9,5		27 ÷ 55
MO-1400\ZN	6x70x214x10,5		55 ÷ 130
MO-1400\ZN + MO-1800\ZN	6x70x214x10,5 + 5,5x54,5x195x12,5		130 ÷ 200
MO-1305 #	3,5x29,8x98x11,5	200 ÷ 600	

it= numero di spire totali
 it= total number of turns
 it= nombre total de spires
 it= número total de espiras

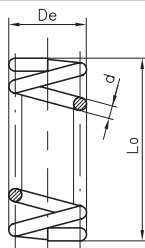

* con membrana rinforzata / with reinforced diaphragm / avec membrane renforcée / con membrana reforzada
 # versione pilotata (fig. 7) / piloted version (fig. 7) / version pilotée (fig. 7) / versión pilotada (fig. 7)

IT

EN

FR

ES

Diagramma perdite di carico regolatori senza filtro (RG/2MC)
Capacity diagram of regulators without filter (RG/2MC)
Diagramme perte de charge régulateurs sans filtre (RG/2MC)
Diagrama de caudales reguladores sin filtro (RG/2MC)

Diagramma calcolato con $P_e = 50$ mbar e regolatore messo fuori servizio
 Diagram calculated with $P_e = 50$ mbar and regulator set out of service
 Diagramme calculé avec $P_e = 50$ mbar et régulateur mis hors service
 Diagrama calculado con $P_e = 50$ mbar y regulador puesto fuera de servicio

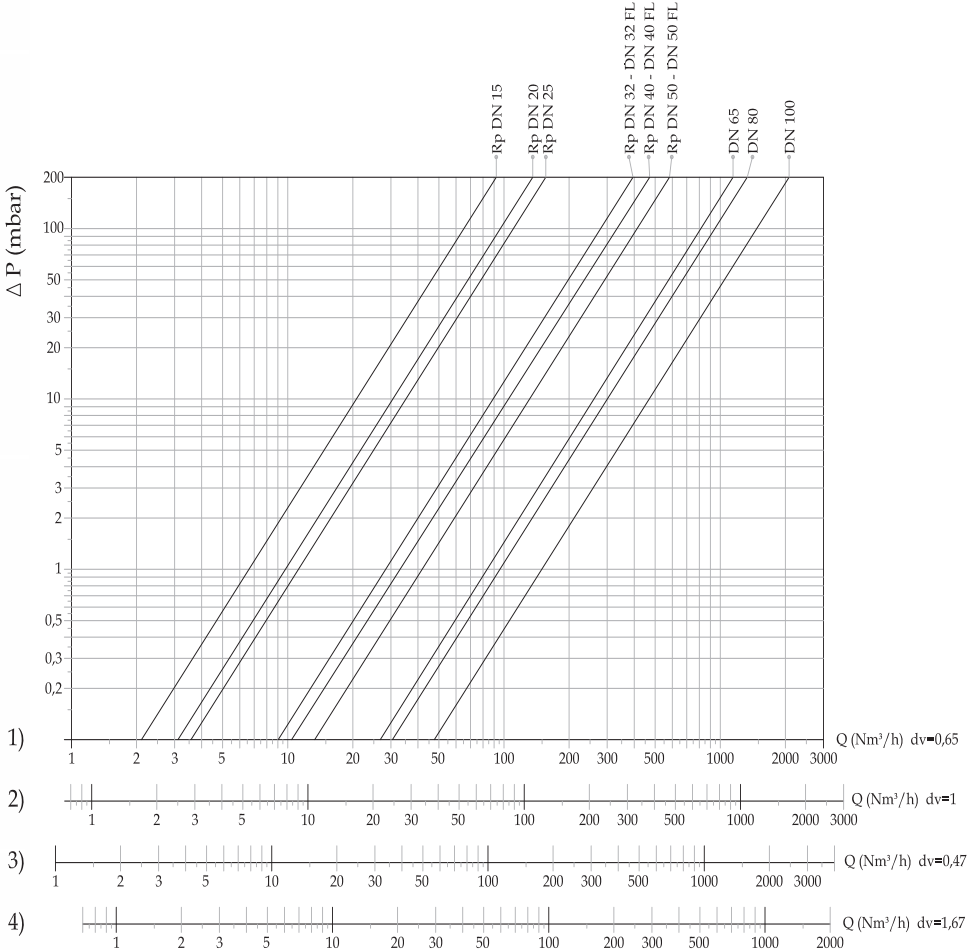

dv = densità relativa all'aria
 dv = density relative to the air
 dv = densité relative à l'air
 dv = densidad relativa del aire

1) metano - methane - méthane - metano
 2) aria - air - air - aire
 3) gas di città - town gas - gaz de ville - gas de ciudad
 4)/gpl - lpg - gaz liquide - gas liquido

Diagramma perdite di carico regolatori con filtro (FRG/2MC)
Capacity diagram of regulators with filter (FRG/2MC)
Diagramme perte de charge régulateurs avec filtre (FRG/2MC)
Diagrama de caudales reguladores con filtro (FRG/2MC)

Diagramma calcolato con $P_e = 50$ mbar e regolatore messo fuori servizio
 Diagram calculated with $P_e = 50$ mbar and regulator set out of service
 Diagramme calculé avec $P_e = 50$ mbar et régulateur mis hors service
 Diagrama calculado con $P_e = 50$ mbar y regulador puesto fuera de servicio

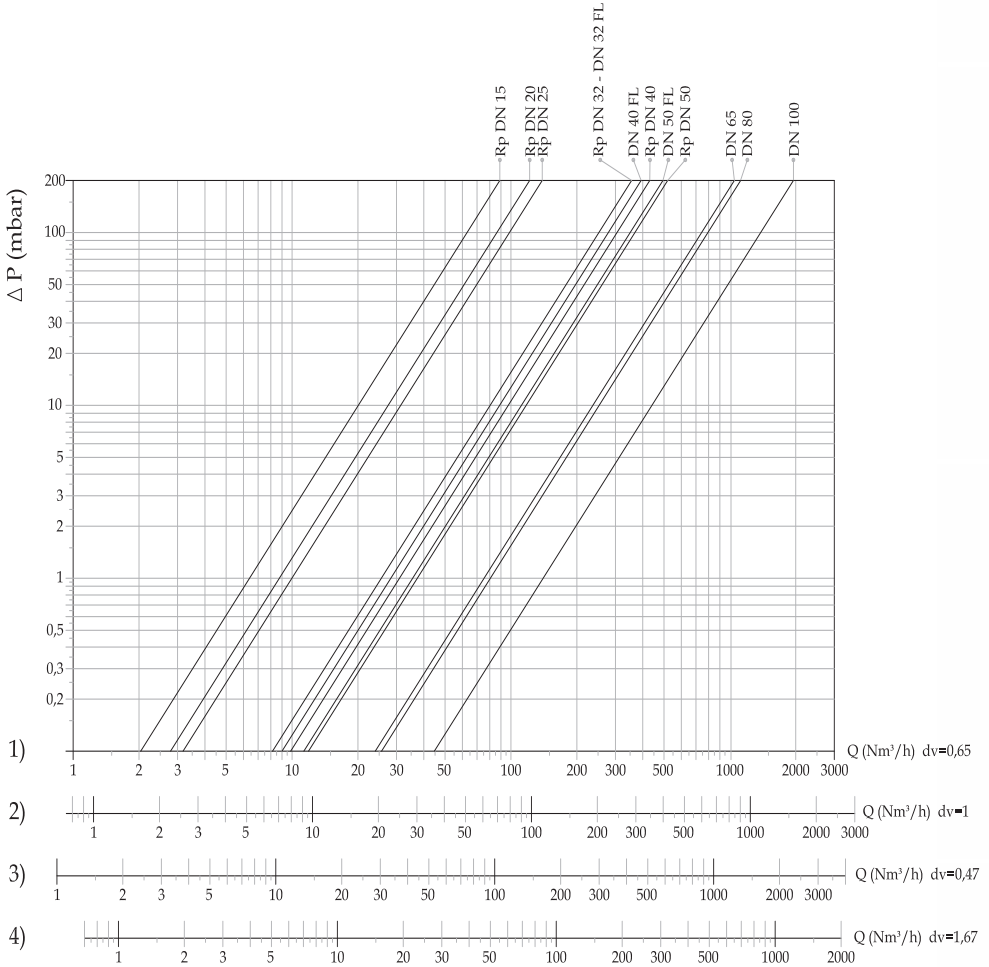

dv = densità relativa all'aria
 dv = density relative to the air
 dv = densité relative à l'air
 dv = densidad relativa del aire

1) metano - methane - méthane - metano
 2) aria - air - air - aire
 3) gas di città - town gas - gaz de ville - gas de ciudad
 4) gpl - lpg - gaz liquide - gas líquido

ATTACCHI FILETTATI NPT / NPT THREADED CONNECTIONS
RACCORDS FILETÉS NPT / CONEXIONES ROSCADAS NPT

richiedere fattibilità / request feasibility / demander la faisabilité / consulte la disponibilidad

Aggiungere la lettera "N" dopo le cifre indicanti gli attacchi	Add the letter "N" after figures denoting the connection	Ajouter la lettre "N" après les chiffres indiquant les connexions	Añadir la letra "N" a continuación de las cifras que indican los diámetros de conexión	Es. / E.g. / Ex. / Ej. FC020020 N 010
--	--	---	--	---

ATTACCHI FLANGIATI ANSI 150 / ANSI 150 FLANGED CONNECTIONS
RACCORDS À BRIDES ANSI 150 / CONEXIONES EMBRIDADAS ANSI 150

richiedere fattibilità / request feasibility / demander la faisabilité / consulte la disponibilidad

Aggiungere la lettera "A" dopo le cifre indicanti gli attacchi	Add the letter "A" after figures denoting the connection	Ajouter la lettre "A" après les chiffres indiquant les connexions	Añadir la letra "A" a continuación de las cifras que indican los diámetros de conexión	Es. / E.g. / Ex. / Ej. FC500020 A 060
--	--	---	--	---

BIOGAS

richiedere fattibilità / request feasibility / demander la faisabilité / consulte la disponibilidad

Aggiungere la lettera "B" dopo le cifre indicanti gli attacchi	Add the letter "B" after figures denoting the connection	Ajouter la lettre "B" après les chiffres indiquant les connexions	Añadir la letra "B" a continuación de las cifras que indican los diámetros de conexión	Es. / E.g. / Ex. / Ej. FC020020 B 010
--	--	---	--	---

ELASTOMERI IN FKM (Viton) / ELASTOMERS IN FKM (Viton)
ÉLASTOMÈRES EN FKM (Viton) / ELASTÓMEROS DE FKM (Viton)

Aggiungere la lettera "V" dopo le cifre indicanti gli attacchi per avere rondella tenuta e membrana di compensazione in FKM.	Add the letter "V" after figures denoting the connection to get the sealing washer and compensation diaphragm in FKM.	Ajouter la lettre "V" après les chiffres indiquant les connexions pour obtenir rondelle de tenue et membrane de compensation en FKM.	Añadir la letra "V" a continuación de las cifras que indican los diámetros de conexión para obtener arandela de estanqueidad y membrana de compensación en FKM.	Es. / E.g. / Ex. / Ej. FC020020 V 010
Aggiungere la lettera "W" dopo le cifre indicanti gli attacchi per avere rondella tenuta, membrana di compensazione e membrana di funzionamento in FKM.	Add the letter "W" after figures denoting the connection to get the sealing washer, compensation diaphragm and working diaphragm in FKM.	Ajouter la lettre "W" après les chiffres indiquant les connexions pour obtenir rondelle de tenue, membrane de compensation et membrane de fonctionnement en FKM.	Añadir la letra "W" a continuación de las cifras que indican los diámetros de conexión para obtener arandela de estanqueidad, membrana de compensación y membrana de trabajo en FKM.	Es. / E.g. / Ex. / Ej. FC020020 W 010

CATAFORESI / CATAPHORESIS
CATAPHORÈSE / CATAFORESIS

Aggiungere la lettera "K" dopo le cifre indicanti gli attacchi	Add the letter "K" after figures denoting the connection	Ajouter la lettre "K" après les chiffres indiquant les connexions	Añadir la letra "K" a continuación de las cifras que indican los diámetros de conexión	Es. / E.g. / Ex. / Ej. FC020020 K 010
--	--	---	--	---

COMBINAZIONI POSSIBILI / POSSIBLE COMBINATIONS
COMBINAISONS POSSIBLES / POSIBLES COMBINACIONES

È possibile combinare tra di loro le versioni. Non serve indicare "BV" in quanto "B" include "V"	It is possible to combine the above mentioned versions. It is not needed to state "BV" as the letter "B" includes "V" too	Les versions peuvent être combinées entre elles. Il n'est pas nécessaire d'indiquer "BV" car "B" comprend "V"	Es posible combinar las versiones entre sí. No es necesario indicar "BV", dado que "B" incluye "V"	Es. / E.g. / Ex. / Ej. FC020020 BK 010
--	---	---	--	--

NOTA: È possibile che alcuni modelli non siano disponibili nelle versioni suddette sia singole e/o combinate. È consigliato chiedere SEMPRE la fattibilità.

NOTE: It is possible certain models are not available on the above mentioned versions, both singles and/or combined too. We suggest to ask ALWAYS for the feasibility.

NOTE: Il est possible que certains modèles ne soient pas disponibles dans les versions uniques et / ou combinées susmentionnées. Il est recommandé de TOUJOURS demander la faisabilité.

NOTA: Puede suceder que algunos modelos no estén disponibles en las versiones citadas, ya sean individuales o combinadas. Se aconseja consultar SIEMPRE la viabilidad.

IT

EN

FR

ES

Pe: 1 ÷ 2 bar

Attacchi filettati / Threaded connections / Raccords filetés / Conexiones roscadas

Attacchi Connections Raccords Conexiones	P2 (mbar)	Filtroregolatore Filter regulator Filtre régulateur Filtroregulador	Regolatore Regulator Régulateur Regulador
		Codice / Code / Code / Códice	Codice / Code / Code / Códice
DN 15	9 ÷ 22	FC020020 010	RC020020 010
	20 ÷ 40	FC020020 020	RC020020 020
	40 ÷ 110	FC020020 030	RC020020 030
	110 ÷ 150	FC020020 040	RC020020 040
	150 ÷ 200	FC020020 050	RC020020 050
	200 ÷ 600	FC020020 060	RC020020 060
DN 20	9 ÷ 22	FC030020 010	RC030020 010
	20 ÷ 40	FC030020 020	RC030020 020
	40 ÷ 110	FC030020 030	RC030020 030
	110 ÷ 150	FC030020 040	RC030020 040
	150 ÷ 200	FC030020 050	RC030020 050
	200 ÷ 600	FC030020 060	RC030020 060
DN 25	9 ÷ 22	FC040020 010	RC040020 010
	20 ÷ 40	FC040020 020	RC040020 020
	40 ÷ 110	FC040020 030	RC040020 030
	110 ÷ 150	FC040020 040	RC040020 040
	150 ÷ 200	FC040020 050	RC040020 050
	200 ÷ 600	FC040020 060	RC040020 060

IT

EN

FR

ES

Pe: 1 ÷ 2 bar

Attacchi filettati / Threaded connections / Raccords filetés / Conexiones roscadas

IT

EN

FR

ES

Attacchi Connections Raccords Conexiones	P2 (mbar)	Filtroregolatore Filter regulator Filtre régulateur Filtroregulador	Regolatore Regulator Régulateur Regulador
		Codice / Code / Code / Códice	Codice / Code / Code / Códice
DN 32	12 ÷ 35	FC050020 020	RC050020 020
	30 ÷ 50	FC050020 030	RC050020 030
	40 ÷ 60	FC050020 040	RC050020 040
	60 ÷ 95	FC050020 050	RC050020 050
	90 ÷ 190	FC050020 060	RC050020 060
	190 ÷ 400*	FC050030 020	RC050030 020
DN 40	12 ÷ 35	FC060020 020	RC060020 020
	30 ÷ 50	FC060020 030	RC060020 030
	40 ÷ 60	FC060020 040	RC060020 040
	60 ÷ 95	FC060020 050	RC060020 050
	90 ÷ 190	FC060020 060	RC060020 060
	190 ÷ 400*	FC060030 020	RC060030 020
DN 50	12 ÷ 35	FC070020 020	RC070020 020
	30 ÷ 50	FC070020 030	RC070020 030
	40 ÷ 60	FC070020 040	RC070020 040
	60 ÷ 95	FC070020 050	RC070020 050
	90 ÷ 190	FC070020 060	RC070020 060
	190 ÷ 400*	FC070030 020	RC070030 020

* con membrana rinforzata / with reinforced diaphragm / avec membrane renforcée / con membrana reforzada

Pe: 1 ÷ 2 bar

Attacchi flangiati / Flanged connections / Raccords à brides / Conexiones embrizadas

Attacchi Connections Raccords Conexiones	P2 (mbar)	Filtroregolatore Filter regulator Filtre règleur Filtroregulador		Regolatore Regulator Regulateur Regulador	
		Codice / Code / Code / Código		Codice / Code / Code / Código	
DN 25	9 ÷ 22	FC250020	010	RC250020	010
	20 ÷ 40	FC250020	020	RC250020	020
	40 ÷ 110	FC250020	030	RC250020	030
	110 ÷ 150	FC250020	040	RC250020	040
	150 ÷ 200	FC250020	050	RC250020	050
	200 ÷ 600	FC250020	060	RC250020	060
DN 32	12 ÷ 35	FC320020	020	RC320020	020
	30 ÷ 50	FC320020	030	RC320020	030
	40 ÷ 60	FC320020	040	RC320020	040
	60 ÷ 95	FC320020	050	RC320020	050
	90 ÷ 190	FC320020	060	RC320020	060
	190 ÷ 400*	FC320030	020	RC320030	020
DN 40	12 ÷ 35	FC400020	020	RC400020	020
	30 ÷ 50	FC400020	030	RC400020	030
	40 ÷ 60	FC400020	040	RC400020	040
	60 ÷ 95	FC400020	050	RC400020	050
	90 ÷ 190	FC400020	060	RC400020	060
	190 ÷ 400*	FC400030	020	RC400030	020
DN 50	12 ÷ 35	FC500020	020	RC500020	020
	30 ÷ 50	FC500020	030	RC500020	030
	40 ÷ 60	FC500020	040	RC500020	040
	60 ÷ 95	FC500020	050	RC500020	050
	90 ÷ 190	FC500020	060	RC500020	060
	190 ÷ 400*	FC500030	020	RC500030	020

* con membrana rinforzata / with reinforced diaphragm / avec membrane renforcée / con membrana reforzada

IT

EN

FR

ES

Pe: 1 ÷ 2 bar

Attacchi flangiati / Flanged connections / Raccords à brides / Conexiones embridadas

Attacchi Connections Raccords Conexiones	P2 (mbar)	Filtroregolatore Filter regulator Filtre régulateur Filtroregulador	Regolatore Regulator Regulateur Regulador
		Codice / Code / Code / Código	Codice / Code / Code / Código
DN 65	7 ÷ 18	FC080020 010	RC080020 010
	13 ÷ 27	FC080020 020	RC080020 020
	22 ÷ 50	FC080020 030	RC080020 030
	50 ÷ 130	FC080020 040	RC080020 040
	110 ÷ 200	FC080020 050	RC080020 050
	200 ÷ 600 #	FC080062 060	RC080062 060
DN 80	7 ÷ 18	FC090020 010	RC090020 010
	13 ÷ 27	FC090020 020	RC090020 020
	22 ÷ 50	FC090020 030	RC090020 030
	50 ÷ 130	FC090020 040	RC090020 040
	110 ÷ 200	FC090020 050	RC090020 050
	200 ÷ 600 #	FC090062 060	RC090062 060
DN 100	7 ÷ 16	FC100020 010	RC100020 010
	15 ÷ 27	FC100020 020	RC100020 020
	27 ÷ 55	FC100020 030	RC100020 030
	55 ÷ 130	FC100020 040	RC100020 040
	130 ÷ 200	FC100020 050	RC100020 050
	200 ÷ 600 #	FC100062 060	RC100062 060

versione pilotata (fig. 7) / piloted version (fig. 7) / version pilotée (fig. 7) / versión pilotada (fig. 7)

**Kit membrane / Diaphragms kit
Kit de membrana / Kit de membrana**

Attacchi / Connections Raccordi / Conexiones	Codice / Code Code / Código
DN 15 - DN 20 - DN 25	KIT-ME2MC 25
DN 32 - DN 40 - DN 50	KIT-ME2MC 50
DN 32* - DN 40* - DN 50*	KIT-ME2MC 50-R
DN 65 - DN 80	KIT-ME2MC 80
DN 65 # - DN 80 #	KIT-ME2MC 80-R
DN 100	KIT-ME2MC 100
DN 100 #	KIT-ME2MC 100-R



**Cartucce filtranti / Filtering cartridges
Cartouches filtrantes / Cartuchos de filtro**

Attacchi / Connections Raccordi / Conexiones	Codice / Code Code / Código
DN 15 - DN 20 - DN 25	OF-0256
DN 32 - DN 40 - DN 50	OF-0265
DN 32 FL - DN 40 FL - DN 50 FL	OF-0265X
DN 65 - DN 80	OF-0286
DN 100	OF-0296



* con membrana rinforzata / with reinforced diaphragm / avec membrane renforcée / con membrana reforzada
versione pilotata (fig. 7) / piloted version (fig. 7) / version pilotée (fig. 7) / versión pilotada (fig. 7)

IT

EN

FR

ES

Ci riserviamo qualsiasi modifica tecnica e costruttiva.
We reserve the right to any technical and construction changes.
Nous nous réservons le droit de toute modification technique et constructive.
Nos reservamos el derecho de realizar cualquier cambio técnico y estructural.

The logo for MADAS features the word "MADAS" in a bold, red, sans-serif font. The text is centered and flanked by two thick, black horizontal bars, one above and one below, which are slightly wider than the text itself. A registered trademark symbol (®) is positioned to the upper right of the word "MADAS".

MADAS®