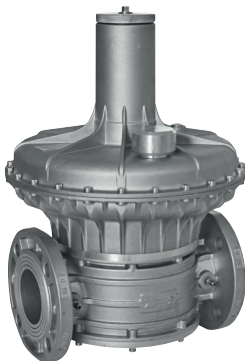
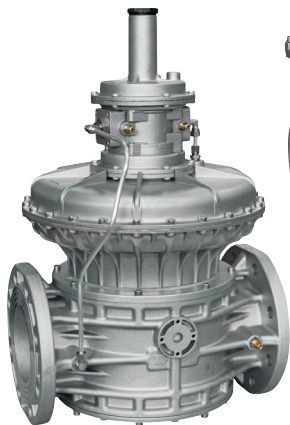

REGOLATORE DI PRESSIONE PER GAS
 GAS PRESSURE REGULATOR
 REGULATEUR DE PRESSION POUR GAZ
 REGULADOR DE PRESIÓN PARA GAS

RG/2MCS

RG/2MBZ

II 2G - II 2D

0497

MADE IN ITALY

	IT	EN	FR	ES
Range pressione di esercizio Operating pressure range Plage de pression de fonctionnement Rango de la presión de funcionamiento	Pe: 0,5÷5 bar			
Attacchi flangiati/ Flanged connections Raccords à brides / Conexiones embreadas	DN 65 - DN 80 - DN 100			
Norma di riferimento / Reference standard Norme de référence / Patrón de referencia	EN 88-2			
In conformità a * In conformity with * Conforme a * Conforme *	Direttiva PED 2014/68/UE	PED Directive 2014/68/EU	Directive PED 2014/68/UE	Directiva PED 2014/68/UE

INDICE - INDEX - INDEX - ÍNDICE

IT

	pag.
Italiano	3
English	13
Français	23
Español	33
Portate regolatori (tabella 1a-1b)	43
Capacities of regulators (table 1a-1b)	
Débit des régulateurs (tableau 1a-1b)	
Caudal de los reguladores (tabla 1a-1b)	

EN

Disegni - Drawings - Dessins - Diseños	45
Dimensioni (tabella 2a-2b)	49
Dimensions (table 2a-2b)	
Dimensions (tableau 2a-2b)	
Dimensiones (tabla 2a-2b)	
Caratteristiche molle di regolazione (tabella 3a-3b-3c)	51
Regulation spring data (table 3a-3b-3c)	
Caracteristiques des ressorts de réglage (tableau 3a-3b-3c)	
Características muelles de regulación (tabla 3a-3b-3c)	

FR

Codifica prodotto / Product encoding / Codification du produit / Codificación del producto	54
--	----

ES

1.0 - GENERAL INFORMATION

This manual shows you how to safely install, operate and use the device.

The instructions for use **ALWAYS** need to be available in the facility where the device is installed.

ATTENTION: installation/maintenance needs to be carried out by qualified staff (as explained in section 1.3) using suitable personal protective equipment (PPE).

For any information pertaining to installation/maintenance or in case of problems that cannot be solved with the instructions, contact the manufacturer at the address and phone numbers provided on the last page.

1.1 - DESCRIPTION

Device which supplies a preset and constant "downstream" pressure value (Pa) (within the intended operating limits) according to variations in the inlet pressure (Pe) and/or the flow rate (Q). The compensated obturator ensures precision when adjusting the outlet pressure (Pa) even with high and sudden variations in the inlet pressure.

These regulators are used in plants where natural gas, LPG or other non-corrosive gases (dry gases) are used.

Reference standards: EN 88-2 – EN 13611.

They can be equipped with the following safety devices and accessories according to the system requirements:

- **downstream overpressure shut off device (OPSO - only RG/2MBZ):** stops supply when the regulator outlet pressure exceeds the setting value of the device. The OPSO device is always present on these devices.
- **downstream minimum pressure shut off device (UPS0 - only RG/2MBZ):** stops supply when the regulator outlet pressure drops below the setting value of the device. It also intervenes in the event of an upstream power failure. They can also be supplied without the UPSO device.
- **relief valve:** discharges small gas flows outwards if overpressure occurs downstream of the regulator. This discharge can be conveyed outwards if the installation is in a poorly ventilated environment. They can also be supplied without the relief valve.
- **outlet pressure test nipple.**

1.2 - KEY TO SYMBOLS



DANGER: In the event of inobservance, this may cause damage to tangible goods.



DANGER: In the event of inobservance, this may cause damage to tangible goods, to people and/or pets.



ATTENTION: Attention is drawn to the technical details intended for qualified staff.

1.3 - QUALIFIED STAFF

These are people who:

- Are familiar with product installation, assembly, start-up and maintenance;
- Know the regulations in force in the region or country pertaining to installation and safety;
- Have first-aid training.



1.4 - USING NON-ORIGINAL SPARE PARTS

- To perform maintenance or change parts (e.g. calibration springs, etc.) **ONLY** manufacturer-recommended spare parts must be used. Using different parts not only voids the product warranty, it could compromise correct device operation.
- The manufacturer is not liable for malfunctions caused by unauthorised tampering or use of non-original spare parts.



1.5 - IMPROPER USE

- The product must only be used for the purpose it was built for.
- It is not allowed to use fluids other than those expressly stated.
- The technical data provided on the rating plate must not, under any circumstances, be exceeded. The end user or installer is in charge of implementing correct systems to protect the device, which prevent the maximum pressure indicated on the rating plate from being exceeded.
- The manufacturer is not responsible for any damage caused by improper use of the device.

2.0 - TECHNICAL DATA

• Use	: non-aggressive gases of the three families (dry gases)
• Ambient temperature (TS)	: -20 ÷ +60°C
• Minimum operating pressure	: 0.5 bar
• Max operating pressure	: 5 bar
• Allowable pressure PS	: 5 bar
• Safety shut offs closing time	: < 1 s
• Accuracy class	: AC=10 - (Pa ± 10%)
• Overpressure shut off accuracy unit	: AG=10
• Closing pressure class	: SG=30
• Relief valve	: tested according to the indications in EN 334
• Connecting the vent	: G 3/4
• Mechanical strength	: Group 2 (according to EN 13611)
• Flanged connections that can couple with PN 16 flanges	: (DN 65 - DN 80 - DN 100) ISO 7005 / EN 1092-1
• ANSI 150 flanged connections	: on request
• In compliance with	: PED Directive 2014/68/EU - ATEX Directive 2014/34/EU

2.1 - MODEL IDENTIFICATION (for configurations see page 54 ÷ 58)

RG/2MCS: Pressure regulator - without safety shut-offs

RG/2MBZ: Pressure regulator - with safety shut-offs

3.0 - COMMISSIONING THE DEVICE



3.1 - OPERATIONS PRIOR TO INSTALLATION

- It is necessary to close the gas upstream of the device prior to installation;
- Make sure that the line pressure **DOES NOT EXCEED** the maximum pressure declared on the product label;
- Protective caps (if any) must be removed prior to installation;
- The pipes and inside of the device must be clear of any foreign bodies;

• IMPORTANT:

- to avoid possible pumping and/or disturbances in the gas flow, a straight pipe section equal to at least 5 DN must be installed (downstream of the regulator);
 - install manual gas closing devices (e.g. ball valves) upstream and downstream of the regulator to protect it from any pipe leak test;
 - do consider that if the regulator is equipped with a relief valve, the latter is suitable for small quantities of gas to be discharged and CANNOT replace the relief valve installed separately as a specific device;
-
- make sure the inlet and outlet counter-flanges are perfectly coaxial and parallel in order to prevent unnecessary mechanical stress to the body. Also calculate the space to insert the seal gasket;
 - With regard to tightening operations, equip yourself with one or two calibrated torque wrenches or other controlled locking tools;
 - With outdoor installation, it is advisable to install a protective roof to prevent rain from oxidising or damaging parts of the device.



- According to the plant geometry, check the risk of an explosive mixture arising inside the piping;
- If the regulator is installed near other devices or as part of an assembly, compatibility between the regulator and these devices must be evaluated beforehand;
- Provide a protection against impacts or accidental contacts if the device is accessible to unqualified personnel.



3.2 - INSTALLATION (see examples in 3.4)

- Assemble the device by flanging it, with the due seals, onto the plant with pipes whose flanges are consistent with the connection being attached. The gaskets must be free from defects and must be centred between the flanges;
- If, after installing the gaskets, there is still too much space in between, do not try to reduce said gap by excessively tightening the bolts of the device;
- The arrow, shown on the body (**5**) of the device, needs to be pointing towards the application;
- Insert the relative washers inside the bolts in order to prevent damage to the flanges during the tightening stage;
- When tightening, be careful not to “pinch” or damage the gasket;
- Tighten the nuts or bolts gradually, in a “cross” pattern (see the example alongside);
- Tighten them, first by 30%, then by 60% and finally 100% of the maximum torque (see the example alongside, according to EN 13611);
- Tighten each nut and bolt again clockwise at least once, until the maximum torque has been achieved uniformly;
- The regulator is normally positioned before the application. It can be installed in any position even if the installation shown in 3.4 (installation examples) is preferred. A pressure test nipple (**12**) can be found outside the regulator, downstream from it, to control the regulation pressure (Pa);
- **IMPORTANT:** it is necessary, using the appropriate fitting (**4**), to connect the downstream pulse outlet of the regulator (see installation examples) using a special pipe. For 2MBZ versions (equipped with safety shut-offs), the shut-off downstream of the regulator must also be connected by means of suitable fittings and pipes using the tap connection (**21**) (see installation example 2);
- Drain the relief valve (if any) outwards (as shown in 3.4). To do so, in the piloted 2MCS version (see fig.2), it is necessary to remove the dust cap (**32**);
- It is always recommended to install a compensation joint;
- During installation, avoid debris or metal residues from getting into the device;
- To guarantee mechanical tension-free assembly, we recommend using compensating joints, which also adjust to the pipe's thermal expansion;
- If the device is to be installed in a ramp, it is the installer's responsibility to provide suitable supports or correctly sized supports, to properly hold and secure the assembly. Never, for any reason whatsoever, leave the weight of the ramp only on the connections (threaded or flanged) of the individual devices;
- In any case, after installation check the tightness of the system, without subjecting the diaphragm of the regulator (therefore, the downstream pipe section) to a pressure higher than 300 mbar (valid only for versions with standard working diaphragm). For versions with reinforced diaphragm, check the tightness with a pressure equal to 1.5 times the regulator setting pressure.

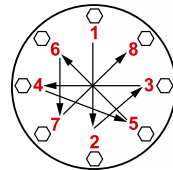

Diameter	DN 65	DN 80	DN 100
Max. torque (N.m)	50	50	80

3.3 - INSTALLATION IN PLACES WHERE THERE IS THE RISK OF EXPLOSION (DIRECTIVE 2014/34/EU)

The regulator complies with Directive 2014/34/EU (formerly 94/9/EC) as group II equipment, category 2G and as group II equipment, category 2D; consequently, it is suited for installation in zones 1 and 21 (in addition to zones 2 and 22) as classified in Annex I of Directive 99/92/EC. The regulator is not suited for use in zones 0 and 20 as defined in the aforementioned Directive 99/92/EC. To determine the qualification and size of the danger zones, please refer to standard IEC EN 60079-10-1.

If installed and subject to maintenance in full compliance with all conditions and technical instructions provided in this manual, the device does not pose a source of specific hazards: in particular, under conditions of normal operation, the regulator is expected to emit a flammable substance into the atmosphere only occasionally, and specifically:

The regulator can be dangerous with respect to the presence of other devices nearby if the integrated relief valve is triggered or if the working diaphragm (**16**) or the blocking diaphragm (**30**) fails. If the diaphragm fails, the regulator becomes a source of explosive atmosphere emission of continuous degree and, as such, it can generate hazardous areas 0 as defined in Directive 99/92/EC.

In particularly critical installation conditions (unattended areas, poor maintenance or poor ventilation) and especially if there are potential sources of ignition and/or hazardous equipment near the regulator in regular operation, as they may generate electric arcs or sparks, a preliminary assessment of the compatibility between the regulator and such equipment must be carried out. In any case, every useful precaution must be adopted so as to prevent the regulator from generating zones 0: for example, annually verify regular operation, possibility of changing the degree of emission of the source or intervening on the explosive substance discharge by directing it outwards. To do so, where present, remove the dust caps (**31**) and (**32**) by connecting the specific pipe (respectively, G 3/4 and G 1/8) conveying it to the outside (see installation examples in 3.4).

3.4 - GENERAL EXAMPLES OF INSTALLATION

EXAMPLE 1 (RG/2MCS)

1. Expansion joint/anti-vibration mount
2. Upstream ball valve
- 3. RG/2MCS pressure regulator**
4. Ball valve downstream of the regulator
5. Vent valve
6. MVS/1 relief valve
7. Low pressure gauge and relative button
8. High pressure gauge and relative button

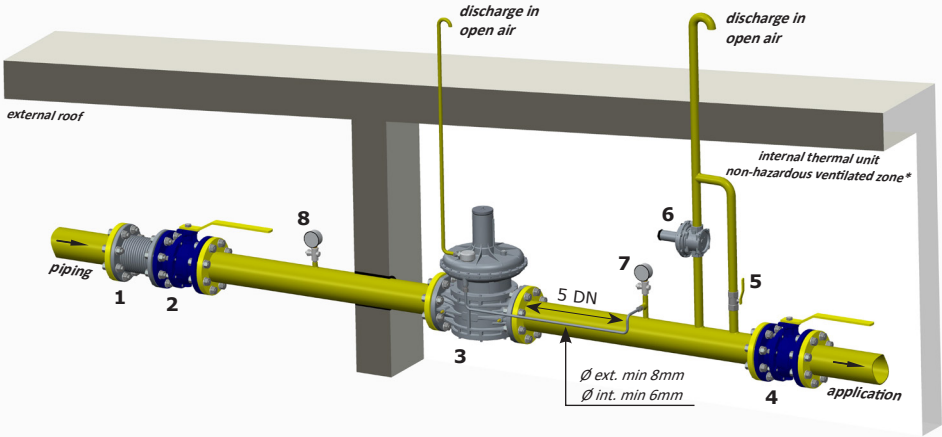

* if the zone is ATEX classified follow the indications of 3.3

EXAMPLE 2 (RG/2MBZ)

1. Expansion joint/anti-vibration mount
2. Upstream ball valve
- 3. RG/2MBZ pressure regulator**
4. Ball valve downstream of the regulator
5. Vent valve
6. MVS/1 relief valve
7. Low pressure gauge and relative button
8. High pressure gauge and relative button

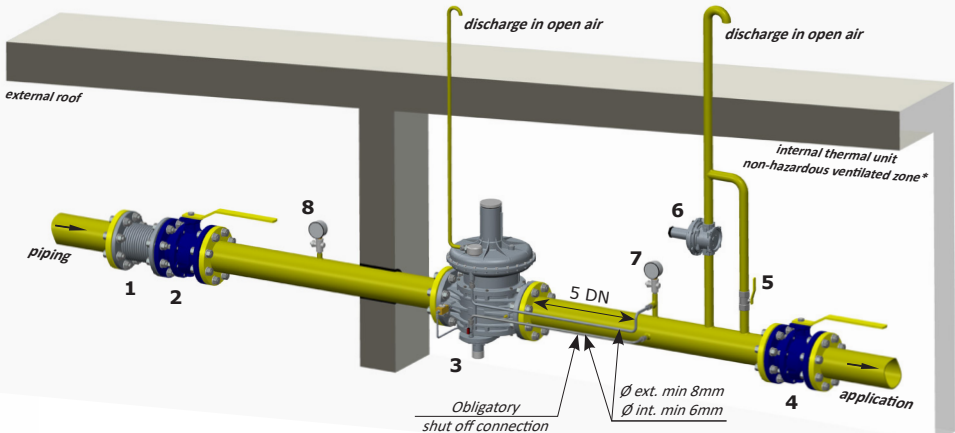

* if the zone is ATEX classified follow the indications of 3.3



4.0 - MANUAL RESET (only RG/2MBZ)

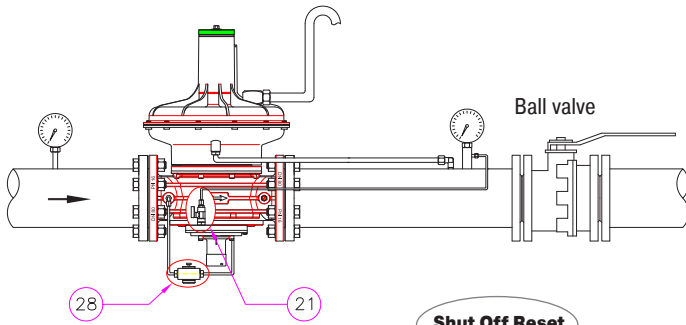
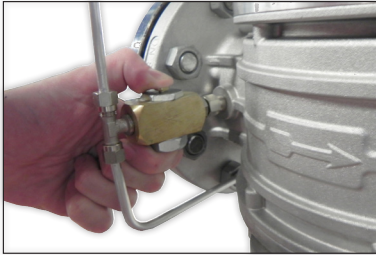
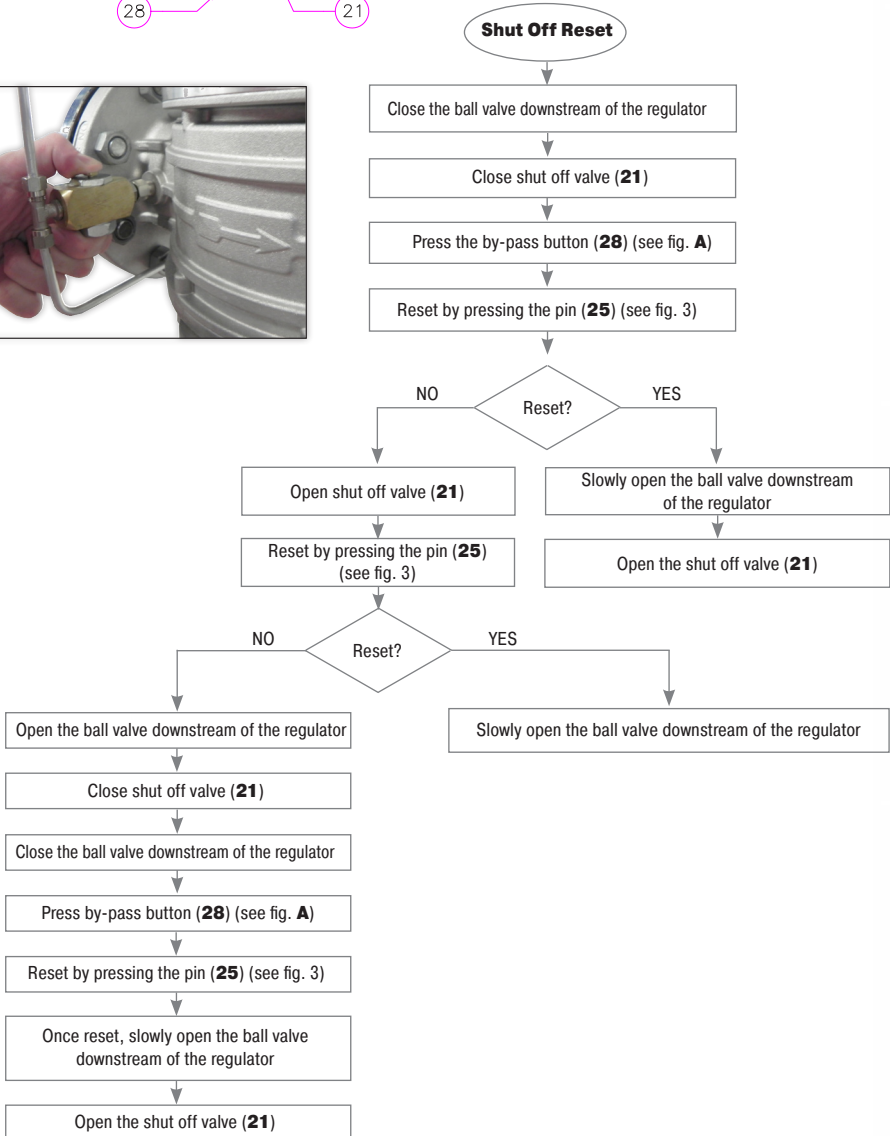

fig. A



Shut Off Reset





5.0 - FIRST START-UP

Before commissioning, verify that:

- all of the instructions on the rating plate, including the direction of flow, are observed;
- the holes of the dust caps **(31)** and **(32)** and of the discharge **(18)** are not clogged (regulator and shut off);
- **IMPORTANT:** The leak test of the piping must be performed without subjecting the diaphragm of the regulator (therefore, the downstream pipe section) to a pressure higher than 300 mbar (for reinforced diaphragm 1.5 times the regulator setting pressure). Use special manual gas closing devices to avoid damaging the regulator;
- The pressurisation manoeuvre of the equipment must be carried out very slowly so as to avoid possible damage.

NOTE: under no circumstances should a blind cap be installed in place of dust caps **(31)** and **(32)** and of discharge caps **(18)** as the regulator and/or the safety shut offs may not work;

- Close the ball valve downstream of the regulator and partially open the downstream relief valve;
- Slowly open the upstream shut-off devices;
- Close the vent valve;
- Proceed by manually resetting the regulator (see 4.0);
- Close the downstream valve so as to close the regulator (the Pa value increases the SG value to fully close the obturator);
- Check the tightness of the system gaskets and check the internal/external tightness of the regulator, of the relief valve and of the external sensor tube, if applicable;
- Slowly open the downstream valve and the shut-off valve;
- Check the operation of the regulator.



6.0 - SETTING

The RG/2MCS models are **NOT** equipped with safety shut offs (OPSO - UPSO).

Before carrying out the operations, make sure that the supplied spring/s is/are suitable for the desired Pa - OPSO - UPSO and differential relief valve fields.

- Equip yourself with an adequate pressure gauge to control the pressure downstream of the regulator.
- For versions with relief **(2MCS and 2MBZ, fig. 1 and 3)** use a 10 mm hex socket wrench (commercial wrench) with max ext. Ø of not more than 15 mm.
- For versions with pilot operated relief **(2MCS fig. 2)** use an 8 mm hex socket wrench (commercial wrench) with max ext. Ø of not more than 12 mm.

If calibration is needed: the following must be calibrated in the **RG/2MCS** versions: P2 - Relief

the following must be calibrated in the **RG/2MBZ** versions: UPSO - OPSO - P2 - Relief

Calibration of the P2 must be carried out with the system in flow.

Before starting the system (in versions with relief), loosen and remove the cap **(1)** and fully tighten the relief adjustment nut **(19)**.

Before starting the system (only in versions with safety shut offs **RG/2MBZ**):

- Loosen the shut off cap **(23)**.
- Loosen and remove the end part of the reset pin **(25)**.
- Using the appropriate wrench **(29)** fully tighten the OPSO adjustment screw **(24)** and position the UPSO adjustment screw **(26)** at a minimum.

6.1 - Adjusting the outlet pressure (Pa)

The outlet pressure Pa (unless specifically requested) is factory-set with the regulator installed as indicated in 3.4 and with the adjustment screw **(2)** set approximately at the minimum setting value. The safety shut offs/relief valve are set accordingly; If the regulator is installed in different positions, check and reset the outlet pressure Pa, and consequently the devices incorporated in the regulator;

Adjust the outlet pressure as follows:

- in versions with relief (fig.1 and 3), act directly on the adjustment screw **(2)**; in versions without relief (fig.1 and 3) it is necessary, before proceeding, to loosen the cap **(1)**. In the piloted versions (fig.3) it is still necessary to loosen the cap **(1)**.
- Unscrew the adjustment screw **(2)** and set it to the minimum setting allowed;
- Start the system or make sure there is a minimum flow downstream of the regulator;
- To increase the pressure calibration downstream of the regulator, tighten the adjustment screw **(2)** to the desired value. Perform the reading with a calibrated pressure gauge, installed downstream of the regulator to at least 5 DN (see examples in 3.4);
- If it has been removed, screw the cap **(1)** back on and if necessary, seal it in that position using the appropriate seal holes (if any);
- Use pressure outlets **(12)** on the device only for zero flow or very low flow measurements.

6.2 - Adjusting the minimum pressure shut off (UPSO)

NOTE: to act on the UPSO adjustment screw **(26)**, it is necessary to remove (by loosening it) the reset pin **(25)** and then tighten it again to reset the device.

- Unscrew the cap **(23)**;
- Use the supplied key **(29)** to loosen the adjustment ring nut of the minimum shut off **(26)** to the minimum;
- Start the system and reset the shut off device as described in 4.0;
- Reduce the downstream pressure to the desired trigger value;
- Use the supplied key **(29)** to tighten the adjustment ring nut **(26)** until the minimum pressure shut off is triggered.
- Reset the system by following the correct procedure and verify that the trigger value is that desired by repeating the release step 2-3 times;
- If necessary, adjust the trigger value by turning the ring nut **(26)** with the specific key **(29)**;

6.3 - Adjusting the maximum pressure shut off (OPSO)

- Unscrew the cap **(23)**;
- Use the supplied key **(29)** to fully tighten the adjustment ring nut of the maximum shut off **(24)**. To do this, if necessary, remove (by loosening it) the reset pin **(25)***;
- Start the system, reset the shut off device as indicated in 4.0 and make sure that there is no gas consumption (close the applications downstream of the regulator);
- Use an auxiliary gas pressure to slowly increase the downstream pressure to the desired value and simultaneously, use the key supplied **(29)** to loosen the ring nut **(24)** until the device is triggered (so as to avoid having to set the Pa again);
- In both cases, reset the system by following the correct procedure and verify that the trigger value is that desired by repeating the release step 2-3 times;
- If necessary, adjust the trigger value by turning the ring nut **(24)** with the specific key **(29)**.

* It must be tightened again in the original position to reset the device.

6.4 - Adjusting the relief valve (differential DfRv)

NOTE: The relief valve (if any) in these regulators is differential, therefore the range value (DfRv) indicated must be added to the range value of the outlet pressure (Pa).

Example: Pa=32-60 mbar - DfRv=15-40 mbar.

Means that the relief valve can be calibrated from: (Pa min + DfRv min) = 32+15=47 mbar to: (Pa max + DfRv max) = 60+40=100 mbar

Therefore the effective range of the relief valve (in this case) is 47-100 mbar.

- Start the system and set the shut off as described in point 4.0;
- Slowly close the valve downstream of the regulator;
- Loosen and remove the cap (**1**);
- Use the appropriate socket spanner (see fig. 1, 2 and 3) tighten the nut to stroke end (**19**);
- Use the 10 mm socket spanner to press the adjustment nut (**19**) and increase the pressure Pa, reading it on the pressure gauge, up to the desired setting value;
- Without pressing further, slowly loosen the adjustment nut (**19**) until the pressure Pa begins to decrease, shown on the pressure gauge;
- In this case, the relief valve is set to the desired value;
- Remove the socket spanner and close the cap (**1**).



7.0 - RECOMMENDED PERIODIC CHECKS

- Use a suitable calibrated tool to ensure that the bolts are tightened as indicated in 3.2;
 - Check the tightness of the flanged/threaded connections on the system;
 - Check the tightness and operation of the regulator/shut off/relief valve;
- The final user or installer is responsible for defining the frequency of these checks based on the severity of the service conditions.

7.1 - CHECK THAT THE MAXIMUM PRESSURE SHUT OFF VALVE IS WORKING (OPSO)

Reset the shut off device and close the valve downstream of the regulator;

Method 1:

1. Loosen and remove caps (**1**) and (**23**);
2. Use the same tool (shown in fig. 3) to press the nut (**19**) and slowly increase the downstream pressure until the device is triggered;
3. Tighten the caps back to their original position and repeat the Pa setting steps (6.4);

Method 2:

1. Alternatively, use an auxiliary gas pressure to slowly increase the downstream pressure until the device is triggered (so as to avoid having to set the Pa again).

7.2 - CHECK THAT THE MINIMUM PRESSURE SHUT OFF VALVE IS WORKING (UPSO)

- Reset the shut off device and close the ball valve upstream of the regulator;
- Open the relief valve, downstream of the device, partially and slowly. As the outlet pressure decreases slowly it will cause the minimum shut off to trigger at its setting value;
- Repeat the trigger step 2-3 times to make sure that the system functions correctly. Between one trigger and another, set the downstream pressure back to the setting value.

7.3 - CHECK THE TIGHTNESS OF THE DEVICES (OPSO AND UPSO)

- Fully empty the downstream pipe section (wait a few seconds to allow it to empty completely). The downstream pressure must remain at zero when the relief valve is closed.

7.4 - CHECK THAT THE RELIEF VALVE IS WORKING PROPERLY

- Start the system and set the shut off as described in point 4.0;
- Slowly close the valve downstream of the regulator;
- Loosen and remove the cap (1);
- Using an appropriate socket spanner (see fig.1, 2 and 3) to press the adjustment nut (19), increase the pressure Pa above the preset value, while preventing the OPSO shut off from being triggered. Use a calibrated pressure gauge for the reading;
- Remove the socket spanner. The generated overpressure will be discharged outwards and the Pa will begin to decrease to the relief valve setting value. Relief valve operation is verified;
- Close the cap (1);
- Open the relief valve to discharge the created overpressure;
- Close the relief valve (the regulator goes to the closing pressure) and open the ball valve downstream of the regulator.



8.0 - MAINTENANCE



- No maintenance operations need to be carried out inside the device. If operations must be carried out inside the device (changing the spring, replacing the filter, etc.), it is advisable to contact the Technical Department. In any case, before carrying out any dismantling operation on the device, make sure that there is no pressurised gas inside.

9.0 - TRANSPORT, STORAGE AND DISPOSAL

- During transport the material needs to be handled with care, avoiding any impact or vibrations to the device;
- If the product has any surface treatments (ex. painting, cathaphoresis, etc) it must not be damaged during transport;
- The transport and storage temperatures must observe the values provided on the rating plate;
- If the device is not installed immediately after delivery it must be correctly placed in storage in a dry and clean place;
- In humid facilities, it is necessary to use driers or heating to avoid condensation;
- At the end of its service life, the product must be disposed of in compliance with the legislation in force in the country where this operation is performed.

10.0 - WARRANTY

The warranty conditions agreed with the manufacturer at the time of the supply apply.

Damage caused by:

- Improper use of the device;
- Failure to observe the requirements described in this document;
- Failure to observe the regulations pertaining to installation;
- Tampering, modification and use of non-original spare parts;



are not covered by the rights of the warranty or compensation for damage.

The warranty also excludes maintenance work, the assembly of parts or non-original spare parts, making changes to the device and natural wear.

11.0 - RATING PLATE DATA

MADAS [®] s.r.l.		Via Moratello, 5/7 - 37045 Legnago (VR) - Italy www.madas.it	
Mod: RG/2MCS DN 80	PS=Pe: 0,5-5 bar	TS: -20+60°C	
Pa: 32-60 mbar DfRv: 15-40 mbar	AC10 SG30 EN 88-2		
year: 2018 Lot: U1823 14216/00001	  IIG IIG2 IIG2  0497		

RG/2MCS

MADAS [®] s.r.l.		Via Moratello, 5/7 - 37045 Legnago (VR) - Italy www.madas.it	
Mod: RG/2MBZ DN 80	PS=Pe: 0,5-5 bar	TS: -20+60°C	
Pa: 32-60 mbar Wdso: 70-140 mbar	AC10 SG30 AG10 EN 88-2		
Wdsu: 10-30 mbar DfRv: 15-40 mbar	  IIG IIG2 IIG2  0497		
year: 2018 Lot: U1823 14216/00001			

RG/2MBZ

The rating plate data (see examples above) includes the following:



- Manufacturer's name/logo and address (possible distributor name/logo)
- Mod.: = name/model of the device followed by the connection diameter
- PS = Allowable pressure
- Pe = Maximum pressure or inlet pressure range that product operation is guaranteed at
- TS = Temperature range within which product operation is guaranteed
- Pa = Outlet pressure range
- Wdso (if applicable) = OPSO calibration range that can be achieved with the spring provided (without replacing any part)
- AC = Accuracy class Pa
- SG = Closing pressure class
- AG = Overpressure block accuracy unit
- EN 88-2 = Product reference regulation
- Wdsu (if applicable) = UPSO calibration range that can be achieved with the spring provided (without replacing any part)
- DfRv (if applicable) = Differential relief valve range with respect to Pa
- year = Year of manufacture
- Lot = Product serial number (see explanation below)
 - U1823 = Lot issued in year 2018 in the 23rd week
 - 14216 = progressive job order number for the indicated year
 - 00001 = progressive number referring to the quantity of the lot
-  = In compliance with ATEX Dir. followed by the protection mode
-  0497 = In compliance with PED directive followed by the no. of the Notified Body

Tabella 1a - Table 1a - Tableau 1a - Tabla 1a

PORTATE REGOLATORI / CAPACITIES OF REGULATORS / DÉBIT DES RÉGULATEURS / CAUDAL DE LOS REGULADORES
(Nm³/h) Gas naturale - Natural Gas - Gaz naturel - Gas natural

Modello Model Modèle Modelo	Pe (bar)	Pa = 20 mbar	Pa = 30 mbar	Pa = 50 mbar	Pa = 100 mbar	Pa = 200 mbar
DN 65	0,5	1000	1100	1090	1100	1050
	1	1490	1240	1450	1670	1600
	2	1800	2125	1850	2100	2400
	3	1625	2230	2230	2250	2600
	4	1670	1380	2400	2400	2700
	5	1750	1480	1850	1950	2850
DN 80	0,5	1350	1450	1240	1350	1240
	1	1950	2150	2100	2350	2200
	2	2450	2650	3100	3450	3400
	3	2450	2600	2850	3450	3900
	4	2450	2700	3100	3700	3900
	5	2600	2700	3200	3840	4000
DN 100	0,5	1670	1500	1500	1700	1270
	1	2400	2400	2480	2400	2300
	2	3100	3200	3700	3800	3700
	3	3800	3800	4900	5000	5000
	4	3800	3800	4900	5000	5000
	5	3800	3800	4900	5000	5000

Dati ricavati CON L'UTILIZZO del tubetto sensore esterno.
Data obtained USING the external sensor tube.
Données obtenues AVEC L'UTILISATION du tube capteur extérieur.
Datos obtenidos USANDO el tubo sensor externo.

Aria - Air - Air - Aire = 0,806
Gas naturale - Natural Gas - Gaz naturel - Gas natural = 1
Gas di città - Town gas - Gaz de ville - Gas de ciudad = 1.177
GPL - LPG - Gaz de pétrole liquéfié - Gas líquido = 0.62

Tabella 1b - Table 1b - Tableau 1b - Tabla 1b

PORTATE REGOLATORI / CAPACITIES OF REGULATORS / DÉBIT DES RÉGULATEURS / CAUDAL DE LOS REGULADORES
Versioni con membrana rinforzata - Versions with reinforced diaphragm - Versions avec membrane renforcée - Versiones con membrana reforzada
(Nm³/h) Gas naturale - Natural Gas - Gaz naturel - Gas natural

Model	P1 (bar)	P2 (mbar)			
		250	300	400	500
DN 65	0,5	400	500	380	/
	1	800	1000	940	950
	2	2300	2300	2300	2300
	3	3000	3200	3300	3400
	4	3500	3700	3900	4100
	5 - 6	3500	3780	4000	4400
DN 80	0,5	410	600	400	/
	1	800	1030	1000	1000
	2	2300	2350	2350	2350
	3	3500	3500	3500	3500
	4	3700	3800	4400	4500
	5 - 6	3700	3900	4460	4580
DN 100	0,5	530	640	480	/
	1	1050	1200	1280	1300
	2	2100	2500	2800	2900
	3	4300	4300	4400	4500
	4	5000	5000	5200	5400
	5 - 6	5200	5200	5800	5900

Dati ricavati UTILIZZANDO solo il tubetto sensore interno.
Data obtained USING only the internal sensor tube.
Données obtenues AVEC L'UTILISATION uniquement le tube capteur intérieur.
Datos obtenidos USANDO solo el tubo sensor interno.

Aria - Air - Air - Aire = 0,806
Gas naturale - Natural Gas - Gaz naturel - Gas natural = 1
Gas di città - Town gas - Gaz de ville - Gas de ciudad = 1.177
GPL - LPG - Gaz de pétrole liquéfié - Gas líquido = 0.62

fig. 3 - RG/2MBZ

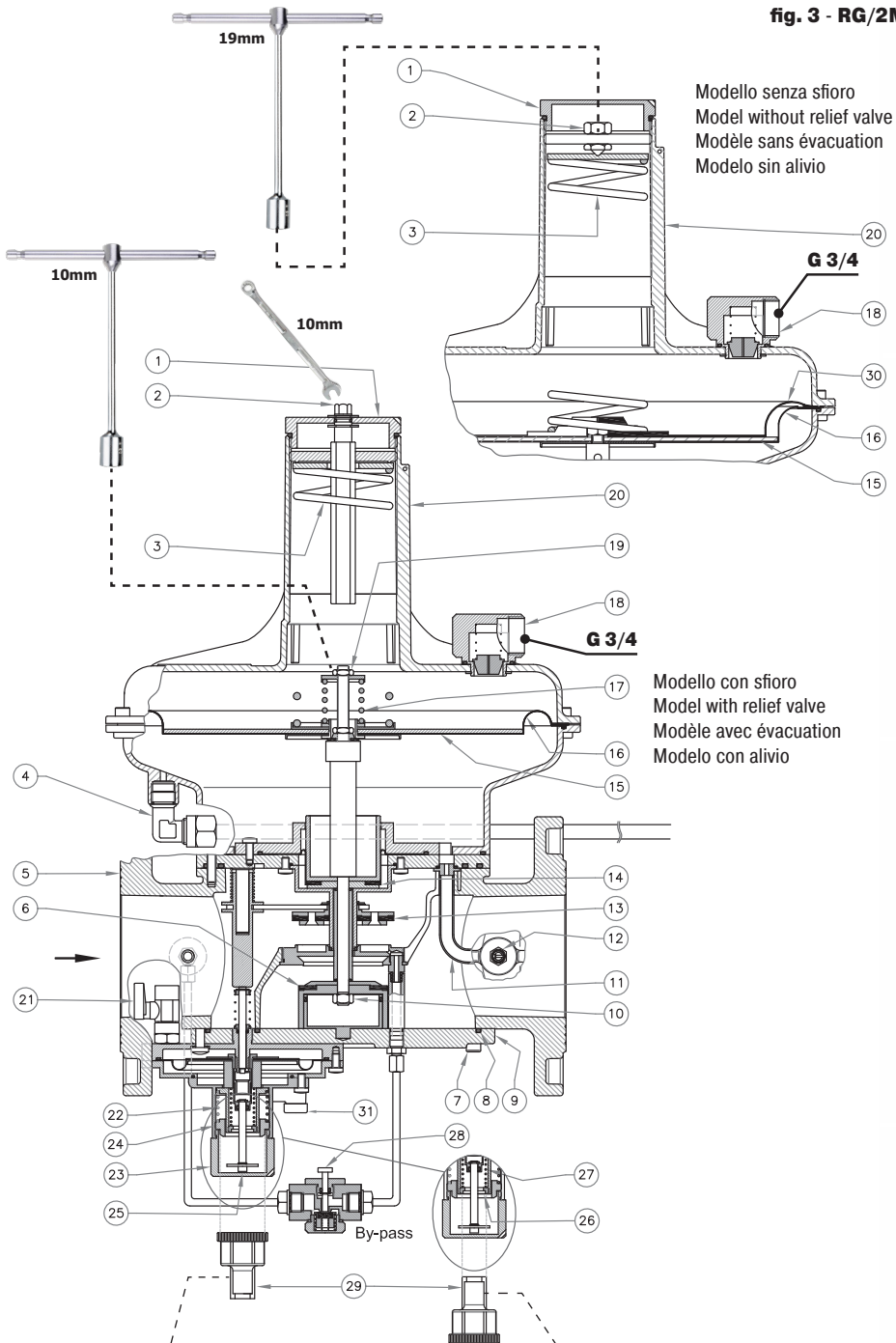

Modello senza sfioro
 Model without relief valve
 Modèle sans évacuation
 Modelo sin alivio

Modello con sfioro
 Model with relief valve
 Modèle avec évacuation
 Modelo con alivio

Per taratura blocco sovrappressione (OPSO)
 For setting the overpressure shut off (OPSO)
 Pour étalonnage blocage surpression (OPSO)
 Para calibración bloqueio de sobrepresión (OPSO)

Per taratura blocco di minima pressione (UPSO)
 For setting the minimum pressure shut off (UPSO)
 Pour étalonnage du blocage de pression minimum (UPSO)
 Para calibración bloqueio de mínima presión (UPSO)

IT**fig. 1, 2 e 3**

1. Tappo di chiusura regolatore
2. Regolazione pressione di uscita (Pa)
3. Molla di taratura Pa
4. Raccordo tubetto sensore esterno
5. Corpo
6. Otturatore (regolatore)
7. Viti di fissaggio fondello
8. O-Ring di tenuta fondello
9. Fondello
10. Dado fissaggio otturatore
11. Tubo sensore interno
12. Presa di pressione (optional)
13. Otturatore (blocco)
14. Membrana di compensazione
15. Disco superiore per membrana
16. Membrana di funzionamento (regolatore)
17. Molla di taratura sfioro
18. Scarico sfioro G 3/4
19. Regolazione sfioro
20. Coperchio superiore
21. Rubinetto
22. Molla di taratura OPSO
23. Tappo di chiusura inferiore
24. Regolazione taratura OPSO
25. Perno di riarmo blocco di sicurezza
26. Regolazione taratura UPSO
27. Molla di taratura UPSO
28. Pulsante by-pass
29. Chiave speciale per taratura (OPSO/USPO)
30. Membrana di sicurezza
31. Tappo antipolvere G 1/8
32. Tappo antipolvere scarico sfioro (solo 2MCS) pilotati

EN**fig. 1, 2 and 3**

1. Regulator closing cap
2. Outlet pressure regulation (Pa)
3. Pa Setting spring
4. External sensor tube fitting
5. Body
6. Obturator (regulator)
7. Bottom fastening screws
8. Bottom sealing O-Ring
9. Bottom
10. Obturator fastening nut
11. Internal sensor tube
12. Pressure test nipple (optional)
13. Obturator (shut off)
14. Compensation diaphragm
15. Top disk for diaphragm
16. Working diaphragm (regulator)
17. Relief valve setting spring
18. Relief discharge G 3/4
19. Relief valve regulation
20. Top cover
21. Valve
22. OPSO Setting spring
23. Lower closing cap
24. OPSO Setting regulation
25. Safety shut off reset pin
26. UPSO Setting regulation
27. UPSO Setting spring
28. By-pass button
29. Special key for setting (OPSO/USPO)
30. Safety diaphragm
31. Dust cap G 1/8
32. Piloted relief discharge dust cap (only 2MCS)

FR**fig. 1, 2 et 3**

1. Bouchon de fermeture régulateur
2. Réglage pression de sortie (Pa)
3. Ressort d'étalonnage Pa
4. Raccord tube capteur externe
5. Corps
6. Obturateur (régulateur)
7. Vis de fixation du fond
8. Joint torique d'étanchéité fond
9. Fond
10. Écrou de fixation de l'obturateur
11. Tube capteur interne
12. Prise de pression (en option)
13. Obturateur (blocage)
14. Membrane de compensation
15. Disque supérieur pour membrane
16. Membrane de fonctionnement (régulateur)
17. Ressort d'étalonnage évacuation
18. Drain d'évacuation G 3/4
19. Réglage évacuation
20. Couvercle supérieur
21. Robinet
22. Ressort d'étalonnage OPSO
23. Bouchon de fermeture inférieur
24. Réglage étalonnage OPSO
25. Pivot de réarmement bloc de sécurité
26. Réglage étalonnage UPSO
27. Ressort d'étalonnage UPSO
28. Bouton by-pass
29. Clé spéciale pour étalonnage (OPSO/USPO)
30. Membrane de sécurité
31. Bouchon anti-poussière G 1/8
32. Bouchon anti-poussière du drain d'évacuation (uniquement 2MCS) piloté

ES**fig. 1, 2 y 3**

1. Tapón de cierre del regulador
2. Regulación de la presión de salida (Pa)
3. Muelle de calibración Pa
4. Rácor tubito sensor externo
5. Cuerpo
6. Obturador (regulador)
7. Tornillos de fijación de la tapa inferior
8. Junta tórica de estanqueidad de la tapa inferior
9. Tapa inferior
10. Tuerca de fijación del obturador
11. Tubo sensor interno
12. Toma de presión (opcional)
13. Obturador (bloqueo)
14. Membrana de compensación
15. Disco superior para membrana
16. Membrana de funcionamiento (regulador)
17. Muelle de calibración alivio
18. Descarga de alivio G 3/4
19. Regulación alivio
20. Tapa superior
21. Grifo
22. Muelle de calibración OPSO
23. Tapón de cierre inferior
24. Regulación de calibración OPSO
25. Perno de rearme del bloqueo de seguridad
26. Regulación de calibración UPSO
27. Muelle de calibración UPSO
28. Botón by-pass
29. Llave especial para calibración (OPSO/USPO)
30. Membrana de seguridad
31. Tapón antipolvo G 1/8
32. Tapón antipolvo descarga de alivio (solo 2MCS) controlado

Tabella 2b - Table 2b - Tableau 2b - Tabla 2b

Dimensioni di ingombro in mm - Overall dimensions in mm - Mesures d'encombrement en mm - Dimensiones en mm

RG/2MBZ

Attacchi flangiati Flanged connections Raccords à bride Conexiones embridadas	fori holes trous orificios	A	B=(D+E)	C	D	E
PN 16 - ANSI 150 DN 65	4	290	540	330	154	386
PN 16 DN 80	8	310	540	330	154	386
ANSI 150 DN 80	4	290	540	330	154	386
PN 16 - ANSI 150 DN 100	8	350	586	330	180	406

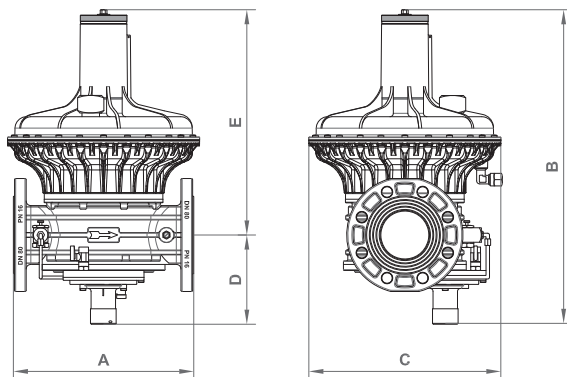

Le dimensioni sono indicative, non vincolanti - The dimensions are provided as a guideline, they are not binding
 Les dimensions sont indicatives, non contraignantes - Las dimensiones son indicativas, no vinculantes

Tabella 3a - Table 3a - Tableau 3a - Tabla 3a

Caratteristiche molle di taratura - Setting springs data
 Caractéristiques ressorts d'étalement - Características de los muelles de calibración

RG/2MCS DN 65 - DN 80			RG/2MCS DN 100		
Molle di taratura Pa / Pa Setting springs Ressorts d'étalement Pa / Muelles de calibración Pa			Molle di taratura Pa / Pa Setting springs Ressorts d'étalement Pa / Muelles de calibración Pa		
Range (mbar)	Codice molla Spring code Code ressort Código muelle	dimensioni in mm dimensions in mm mesures en mm dimensiones en mm (d x De x Lo x it)	Range (mbar)	Codice molla Spring code Code ressort Código muelle	dimensioni in mm dimensions in mm mesures en mm dimensiones en mm (d x De x Lo x it)
13 ÷ 22	MO-1100	4,5x70x200x15,5	13 ÷ 22	MO-1100	4,5x70x200x15,5
20 ÷ 55	MO-1200	5x70x205x9,5	22 ÷ 55	MO-1200	5x70x205x9,5
50 ÷ 130	MO-1400\ZN	6x70x214x10,5	45 ÷ 120	MO-1400\ZN	6x70x214x10,5
110 ÷ 200	MO-1400\ZN + MO-1800\ZN	6x70x214x10,5 + 5,5x54,5x195x12,5	110 ÷ 200	MO-1400\ZN + MO-1800\ZN	6x70x214x10,5 + 5,5x54,5x195x12,5
170 ÷ 400*	MO-1320	3,5x29,8x64x9	170 ÷ 400*	MO-1320	3,5x29,8x64x9
300 ÷ 530*	MO-1305	3,5x29,8x98x11,5	300 ÷ 530*	MO-1305	3,5x29,8x98x11,5
530 ÷ 1300*	MO-2550	4x29x98x8	530 ÷ 1300*	MO-2550	4x29x98x8
800 ÷ 1500*	MO-2580	4,6x29,4x95x9	800 ÷ 1500*	MO-2580	4,6x29,4x95x9
Molle differenziale sfioro / Differential relief valve springs Ressorts différentiel évacuation / Muelle diferencial de alivio			Molle differenziale sfioro / Differential relief valve springs Ressorts différentiel évacuation / Muelle diferencial de alivio		
15 ÷ 50	MO-1320	3,5x29,8x64x9	15 ÷ 50	MO-1320	3,5x29,8x64x9
20 ÷ 100	MO-2550	4x29x98x8	20 ÷ 100	MO-2550	4x29x98x8
40 ÷ 200*	MO-2580	4,6x29,4x95x9	40 ÷ 200*	MO-2155	2x17x29x6

versione pilotata
 # piloted version
 # version pilotée
 # versión pilotada

it= numero di spire totali
 it= total number of turns
 it= nombre total de spires
 it= número total de espiras

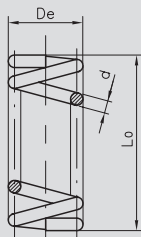

IT

EN

FR

ES

Tabella 3b - Table 3b - Tableau 3b - Tabla 3b

Caratteristiche molle di taratura - Setting springs data
Caractéristiques ressorts d'étalonnage - Características de los muelles de calibración

RG/2MBZ

DN 65 - DN 80

Molle di taratura Pa / Pa Setting springs
Ressorts d'étalonnage Pa / Muelles de calibración Pa

Range (mbar)	Codice molla Spring code Code ressort Código muelle	dimensioni in mm dimensions in mm mesures en mm dimensiones en mm (d x De x Lo x it)
13 ÷ 22	MO-1100	4,5x70x200x15,5
20 ÷ 55	MO-1200	5x70x205x9,5
50 ÷ 130	MO-1400\ZN	6x70x214x10,5
110 ÷ 200	MO-1400\ZN + MO-1800\ZN	6x70x214x10,5 + 5,5x54,5x195x12,5
200 ÷ 350*	MO-1400\ZN + MO-1800\ZN	6x70x214x10,5 + 5,5x54,5x195x12,5
300 ÷ 500*	MO-1400\ZN + MO-1800\ZN	6x70x214x10,5 + 5,5x54,5x195x12,5

Molle di taratura OPSO / OPSO Setting springs
Ressorts d'étalonnage OPSO / Muelles de calibración OPSO

40 ÷ 110	MO-0880	2,2x35x27x3
90 ÷ 210	MO-0890	2,5x30x27x3
180 ÷ 350	MO-0995	3x35x30x3,5
300 ÷ 600*	MO-0990	3x35x33,5x3,5
500 ÷ 900*	MO-0990	3x35x33,5x3,5

Molle di taratura UPSO / UPSO Setting springs
Ressorts d'étalonnage UPSO / Muelles de calibración UPSO

7 ÷ 15	MO-0153	0,9x17x45x7
15 ÷ 25	MO-0204	1x17x40x6
25 ÷ 70	MO-0214	1,3x17x40x6
70 ÷ 110	MO-0215	1,8x18,4x45x8,5
180 ÷ 300*	MO-0215	1,8x18,4x45x8,5

Molle differenziale sfioro / Differential relief valve springs
Ressorts différentiel évacuation / Muelle diferencial de alivio

15 ÷ 50	MO-1320	3,5x29,8x64x9
20 ÷ 100	MO-2550	4x29x98x8

* = versioni con membrana rinforzata. * = versions with reinforced diaphragm. * = versions avec membrane renforcée. * = versiones con membrana reforzada.

it= numero di spire totali
it= total number of turns
it= nombre total de spires
it= número total de espiras



Tabella 3c - Table 3c - Tableau 3c - Tabla 3c

Caratteristiche molle di taratura - Setting springs data
Caractéristiques ressorts d'étalement - Características de los muelles de calibración

RG/2MBZ DN 100

Molle di taratura Pa / Pa Setting springs
Ressorts d'étalement Pa / Muelles de calibración Pa

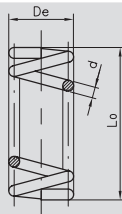
Range (mbar)	Codice molla Spring code Code ressort Código muelle	dimensioni in mm dimensions in mm mesures en mm dimensiones en mm (d x De x Lo x it)
13 ÷ 22	MO-1100	4,5x70x200x15,5
20 ÷ 55	MO-1200	5x70x205x9,5
45 ÷ 120	MO-1400\ZN	6x70x214x10,5
110 ÷ 200	MO-1400\ZN + MO-1800\ZN	6x70x214x10,5 + 5,5x54,5x195x12,5
200 ÷ 350*	MO-1400\ZN + MO-1800\ZN	6x70x214x10,5 + 5,5x54,5x195x12,5
300 ÷ 500*	MO-1400\ZN + MO-1800\ZN	6x70x214x10,5 + 5,5x54,5x195x12,5
Molle di taratura OPSO / OPSO Setting springs Ressorts d'étalement OPSO / Muelles de calibración OPSO		
40 ÷ 110	MO-0880	2,2x35x27x3
90 ÷ 210	MO-0890	2,5x30x27x3
180 ÷ 350	MO-0995	3x35x30x3,5
300 ÷ 600*	MO-0990	3x35x33,5x3,5
500 ÷ 900*	MO-0990	3x35x33,5x3,5
Molle di taratura UPSO / UPSO Setting springs Ressorts d'étalement UPSO / Muelles de calibración UPSO		
7 ÷ 15	MO-0153	0,9x17x45x7
15 ÷ 25	MO-0204	1x17x40x6
25 ÷ 70	MO-0214	1,3x17x40x6
70 ÷ 110	MO-0215	1,8x18,4x45x8,5
180 ÷ 300*	MO-0215	1,8x18,4x45x8,5
Molle differenziale sfioro / Differential relief valve springs Ressorts différentiel évacuation / Muelle diferencial de alivio		
15 ÷ 50	MO-1320	3,5x29,8x64x9
20 ÷ 100	MO-2550	4x29x98x8

* = versioni con membrana rinforzata. * = versions with reinforced diaphragm. * = versions avec membrane renforcée. * = versiones con membrana reforzada.

it= numero di spire totali
it= total number of turns
it= nombre total de spires
it= número total de espiras

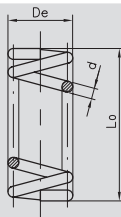

ATTACCHI FLANGIATI ANSI 150 / ANSI 150 FLANGED CONNECTIONS
RACCORDS À BRIDES ANSI 150 / CONEXIONES EMBRIDADAS ANSI 150
 richiedere fattibilità / request feasibility / demander la faisabilité / consulte la disponibilidad

Aggiungere la lettera "A" dopo le cifre indicanti gli attacchi	Add the letter "A" after figures denoting the connection	Ajouter la lettre "A" après les chiffres indiquant les connexions	Añadir la letra "A" a continuación de las cifras que indican los diámetros de conexión	Es. / E.g. / Ex. / Ej. RB09 AZ RCS09 A 0000
--	--	---	--	---

BIOGAS

richiedere fattibilità / request feasibility / demander la faisabilité / consulte la disponibilidad

Aggiungere la lettera "B" dopo la lettera indicante gli attacchi o la configurazione	Add the letter "B" after the letter denoting the connection or configuration	Ajouter la lettre "B" après la lettre indiquant les connexions ou configuration	Añadir la letra "B" a continuación de la letra que indica los diámetros de conexión o la configuración	Es. / E.g. / Ex. / Ej. RB09 BZ RCS09 B 0000
--	--	---	--	---

ELASTOMERI IN FKM (Viton) / ELASTOMERS IN FKM (Viton)
ÉLASTOMÈRES EN FKM (Viton) / ELASTÓMEROS DE FKM (Viton)

Aggiungere la lettera "V" dopo la lettera indicante gli attacchi o la configurazione per avere rondella tenuta e membrana di compensazione in FKM.	Add the letter "V" after the letter denoting the connection or configuration to get the sealing washer and compensation diaphragm in FKM.	Ajouter la lettre "V" après la lettre indiquant les connexions ou configuration pour obtenir rondelle de tenue et membrane de compensation en FKM.	Añadir la letra "V" a continuación de la letra que indica los diámetros de conexión o la configuración para obtener arandela de estanquidad y membrana de compensación en FKM.	Es. / E.g. / Ex. / Ej. RB09 VZ RCS09 V 0000 RB09 WZ RCS09 W 0000
Aggiungere la lettera "W" dopo la lettera indicante gli attacchi o la configurazione per avere rondella tenuta, membrana di compensazione e membrana di funzionamento in FKM.	Add the letter "W" after the letter denoting the connection or configuration to get the sealing washer, compensation diaphragm and working diaphragm in FKM.	Ajouter la lettre "W" après la lettre indiquant les connexions ou configuration pour obtenir rondelle de tenue, membrane de compensation et membrane de fonctionnement en FKM.	Añadir la letra "W" a continuación de la letra que indica los diámetros de conexión o la configuración para obtener arandela de estanquidad, membrana de compensación y membrana de trabajo en FKM.	

CATAFORESI / CATAPHORESIS
CATAPHORÈSE / CATAFORESIS

Aggiungere la lettera "K" dopo la lettera indicante gli attacchi o la configurazione	Add the letter "K" after the letter denoting the connection or configuration	Ajouter la lettre "K" après la lettre indiquant les connexions ou configuration	Añadir la letra "K" a continuación de la letra que indica los diámetros de conexión o la configuración	Es. / E.g. / Ex. / Ej. RB09 KZ RCS09 K 0000
--	--	---	--	---

COMBINAZIONI POSSIBILI / POSSIBLE COMBINATIONS
COMBINAISONS POSSIBLES / POSSIBLES COMBINACIONES

È possibile combinare tra di loro le versioni. Non serve indicare "BV" in quanto "B" include "V"	It is possible to combine the above mentioned versions. It is not needed to state "BV" as the letter "B" includes "V" too	Les versions peuvent être combinées entre elles. Il n'est pas nécessaire d'indiquer "BV" car "B" comprend "V"	Es posible combinar las versiones entre sí. No es necesario indicar "BV", dado que "B" incluye "V"	Es. / E.g. / Ex. / Ej. RB09 BK RCS09 BK 0000
--	---	---	--	--

NOTA: È possibile che alcuni modelli non siano disponibili nelle versioni suddette sia singole e/o combinate. È consigliato chiedere SEMPRE la fattibilità.

NOTE: It is possible certain models are not available on the above mentioned versions, both singles and/or combined too. We suggest to ask ALWAYS for the feasibility.

NOTE: Il est possible que certains modèles ne soient pas disponibles dans les versions uniques et / ou combinées susmentionnées. Il est recommandé de TOUJOURS demander la faisabilité.

NOTA: Puede suceder que algunos modelos no estén disponibles en las versiones citadas, ya sean individuales o combinadas. Se aconseja consultar SIEMPRE la viabilidad.

IT

EN

FR

ES

**Tabella costruzione codici 2MCS - Code table construction 2MCS models
Tableau construction code 2MCS - Tabla de construcción de códigos 2MCS**

Modello Model Modèle Modelo	Attacchi Connections Raccords Conexiones		Pa spring No.	OPSO spring No.	UPSO spring No.	RELIEF spring No.
RCS	09	0000	3	X	X	1
Senza filtro Without filter Sans filtre Sin filtro	DN 50	P1= 0,5 ÷ 5 bar	50 ÷ 130 mbar	senza OPSO without OPSO sans OPSO sin OPSO	senza UPSO without UPSO sans UPSO sin UPSO	15 ÷ 50 mbar
RCS	10	0055	5	X	X	X
Senza filtro Without filter Sans filtre Sin filtro	DN 100	P1= 0,5 ÷ 5 bar pilotato piloted piloteée pilotado	110 ÷ 200 mbar	senza OPSO without OPSO sans OPSO sin OPSO	senza UPSO without UPSO sans UPSO sin UPSO	senza sfioro without relief sans évacuation sin alivio

IT

In tabella sono riportati alcuni esempi per illustrare come è possibile combinare tra di loro le molle di taratura.
Per i modelli "2MCS":

- non possono essere presenti OPSO e UPSO (quindi molle n°2 e n°3 sempre indicate con "X");
- si può omettere lo sfioro contrassegnando con una "X" il campo molla corrispondente (n° 4);
- 0055 è riferito alle versioni pilotate DN 65 - DN 80 - DN 100. Le molle di queste versioni non sono intercambiabili con le versioni non pilotate.

Non tutte le combinazioni sono possibili, devono essere funzionalmente compatibili. Si consiglia di contattare il nostro ufficio commerciale per la conferma della fattibilità.

EN

The table shows some examples to illustrate how you can combine the setting springs.
For "2MCS" models:

- OPSO and UPSO cannot be present (therefore springs no. 2 and no. 3 always indicated with "X");
- the relief valve can be omitted by marking the corresponding spring field (no. 4) with an "X";
- 0055 refers to the piloted versions DN 65 - DN 80 - DN 100. The springs of these versions are not interchangeable with non-piloted versions.

Not all combinations are possible, they must be functionally compatible. It is advisable to contact our sales department for confirmation of feasibility.

FR

Le tableau reporte quelques exemples pour illustrer les possibilités de combinaison des ressorts d'étalonnage entre eux.
Pour les modèles « 2MCS » :

- OPSO et UPSO ne peuvent pas être présents (donc ressorts n° 2 et n° 3 toujours indiqués avec « X ») ;
- il est possible d'exclure l'évacuation en marquant avec un « X » le champ ressort correspondant (n° 4) ;
- 0055 concerne les versions pilotées DN 65 - DN 80 - DN 100. Les ressorts de ces versions ne sont pas interchangeables avec les versions non pilotées.

Pas toutes les combinaisons sont possibles, elles doivent être fonctionnellement compatibles. Il est conseillé de contacter notre bureau commercial pour la confirmation de la faisabilité.

ES

En la tabla aparecen algunos ejemplos para ilustrar cómo se pueden combinar entre ellos los muelles de calibración.
Para los modelos "2MCS":

- no pueden estar presentes OPSO y UPSO (muelles n°2 y n°3 indicados con "X");
- se puede omitir el alivio marcando con una "X" el campo del muelle correspondiente (n.º 4).
- 0055 se refiere a las versiones controladas DN 65 - DN 80 - DN 100. Los muelles de estas versiones no son intercambiables con las versiones no controladas.

No todas las combinaciones son posibles, deben ser funcionalmente compatibles. Se recomienda contactar con nuestra oficina comercial para confirmar la factibilidad.

Tabella 4 - Table 4 - Tableau 4 - Tabla 4
Codifica prodotto / Product encoding / Codification du produit / Codificación del producto

RG/2MCS

Attacchi Connections Raccords Conexiones	N°	Pa (mbar)	N°	DfRv (mbar)	Attacchi flangiati Flanged connections Raccords à bride Conexiones embridadas
					Codice / Code / Code / Código
DN 65	1	13 ÷ 22	1	15 ÷ 50	RCS080000 1XX1
	2	20 ÷ 55	1	15 ÷ 50	RCS080000 2XX1
	3	50 ÷ 130	1	15 ÷ 50	RCS080000 3XX1
	4	110 ÷ 200	2	20 ÷ 100	RCS080000 4XX2
	5	170 ÷ 400 [#]	3	40 ÷ 200 [#]	RCS080055 5XX3
	6	300 ÷ 530 [#]	3	40 ÷ 200 [#]	RCS080055 6XX3
	7	530 ÷ 1300 [#]	3	40 ÷ 200 [#]	RCS080055 7XX3
	8	800 ÷ 1500 [#]	3	40 ÷ 200 [#]	RCS080055 8XX3
DN 80	1	13 ÷ 22	1	15 ÷ 50	RCS090000 1XX1
	2	20 ÷ 55	1	15 ÷ 50	RCS090000 2XX1
	3	50 ÷ 130	1	15 ÷ 50	RCS090000 3XX1
	4	110 ÷ 200	2	20 ÷ 100	RCS090000 4XX2
	5	170 ÷ 400 [#]	3	40 ÷ 200 [#]	RCS090055 5XX3
	6	300 ÷ 530 [#]	3	40 ÷ 200 [#]	RCS090055 6XX3
	7	530 ÷ 1300 [#]	3	40 ÷ 200 [#]	RCS090055 7XX3
	8	800 ÷ 1500 [#]	3	40 ÷ 200 [#]	RCS090055 8XX3
DN 100	1	13 ÷ 22	1	15 ÷ 50	RCS100000 1XX1
	2	22 ÷ 50	1	15 ÷ 50	RCS100000 2XX1
	3	45 ÷ 120	1	15 ÷ 50	RCS100000 3XX1
	4	110 ÷ 200	2	20 ÷ 100	RCS100000 4XX2
	5	170 ÷ 400 [#]	3	40 ÷ 200 [#]	RCS100055 5XX3
	6	300 ÷ 530 [#]	3	40 ÷ 200 [#]	RCS100055 6XX3
	7	530 ÷ 1300 [#]	3	40 ÷ 200 [#]	RCS100055 7XX3
	8	800 ÷ 1500 [#]	3	40 ÷ 200 [#]	RCS100055 8XX3

= versione pilotata. Le tarature contrassegnate con # non sono intercambiabili con le versioni standard (quelle senza #).

= piloted version. Settings marked with # are not interchangeable with standard settings (the one without #).

= version pilotée. Les étalonnages marqués avec # ne sont pas interchangeables avec les versions standards (ceux sans #).

= versión pilotada. Las calibraciones marcadas con # no son intercambiables con las versiones estándar (sin #).

In tabella sono indicati i codici delle versioni più comuni e con sfioro incorporato. Per altre combinazioni vedere indicazioni a pag. 54-55.

The table shows the codes of the more common versions with built-in relief valve. For other combinations see the instructions on page 54-55.

Dans le tableau sont indiqués les codes des versions les plus courantes avec évacuation incorporée. Pour d'autres combinaisons, voir les indications à la page 54-55.

En la tabla se indican los códigos de las versiones más conocidas y con alivio incorporado. Para otras combinaciones, consulte las indicaciones de las páginas 54-55.

**Tabella costruzione codici 2MBZ - Code table construction 2MBZ models
Tableau construction code 2MBZ - Tabla de construcción de códigos 2MBZ**

Modello Model Modèle Modelo	Attacchi Connections Raccords Conexiones	IN/OUT configuration	Pa spring No.	OPSO spring No.	UPS0 spring No.	RELIEF spring No.
--------------------------------------	---	-------------------------	------------------	--------------------	--------------------	----------------------

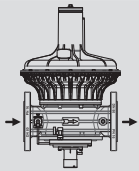
RB	09	Z	3	2	3	1
<u>Senza filtro</u> <u>Without filter</u> <u>Sans filtre</u> <u>Sin filtro</u>	DN 80		50 ÷ 130 mbar	90 ÷ 210 mbar	25 ÷ 70 mbar	15 ÷ 50 mbar

IT

In tabella sono riportati alcuni esempi per illustrare come è possibile combinare tra di loro le molle di taratura.

Per i modelli "2MBZ" DN 65 - DN 80 - DN 100:

- OPSO è sempre presente, si può omettere UPSO (indicare molla n°3 con "X"), si può omettere lo sfioro (indicare molla n°4 con "X");

Non tutte le combinazioni sono possibili, devono essere funzionalmente compatibili. Si consiglia di contattare il nostro ufficio commerciale per la conferma della fattibilità.

EN

The table shows some examples to illustrate how you can combine the setting springs.

For "2MBZ" models DN 65 - DN 80 - DN 100:

- OPSO is always present, UPSO can be omitted (indicate spring no. 3 with "X"), the relief valve can be omitted (indicate spring no. 4 with "X");

Not all combinations are possible, they must be functionally compatible. It is advisable to contact our sales department for confirmation of feasibility.

FR

Le tableau reporte quelques exemples pour illustrer les possibilités de combinaison des ressorts d'étalonnage entre eux.

Pour les modèles « 2MBZ » DN 65 - DN 80 - DN 100 :

- OPSO est toujours présent, il est possible d'exclure UPSO (indiquer le ressort n° 3 avec « X »), il est possible d'exclure l'évacuation (indiquer le ressort n° 4 avec « X ») ;

Pas toutes les combinaisons sont possibles, elles doivent être fonctionnellement compatibles. Il est conseillé de contacter notre bureau commercial pour la confirmation de la faisabilité.

ES

En la tabla aparecen algunos ejemplos para ilustrar cómo se pueden combinar entre ellos los muelles de calibración.

Para los modelos "2MBZ" DN 65 - DN 80 - DN 100:

- OPSO está siempre presente, se puede omitir UPSO (indicar muelle n.º 3 con "X"), se puede omitir el alivio (indicar muelle n.º 4 con "X").

No todas las combinaciones son posibles, deben ser funcionalmente compatibles. Se recomienda contactar con nuestra oficina comercial para confirmar la factibilidad.

IT

EN

FR

ES

Tabella 5 - Table 5 - Tableau 5 - Tabla 5

Codifica prodotto / Product encoding / Codification du produit / Codificación del producto

RG/2MBZ

Attacchi flangiati / Flanged connections / Raccords à bride / Conexiones embreadas

Attacchi Connections Raccords Conexiones	N°	Pa (mbar)	N°	OPSO RANGE (mbar)	N°	UPSO RANGE (mbar)	N°	DfRv (mbar)	Codice Code Code Código	
DN 65	1	13 ÷ 22	1	40 ÷ 110	1	7 ÷ 15	1	15 ÷ 50	RB08Z	1111
	2	20 ÷ 55	1	40 ÷ 110	2	15 ÷ 25	1	15 ÷ 50	RB08Z	2121
	3	50 ÷ 130	2	90 ÷ 210	3	25 ÷ 70	1	15 ÷ 50	RB08Z	3231
	4	110 ÷ 200	3	180 ÷ 350	4	70 ÷ 110	2	20 ÷ 100	RB08Z	4342
	5	200 ÷ 350*	4	300 ÷ 600	4	70 ÷ 110	X	-	RB08Z	544X
	6	300 ÷ 500*	5	500 ÷ 900*	5	180 ÷ 300*	X	-	RB08Z	655X
DN 80	1	13 ÷ 22	1	40 ÷ 110	1	7 ÷ 15	1	15 ÷ 50	RB09Z	1111
	2	20 ÷ 55	1	40 ÷ 110	2	15 ÷ 25	1	15 ÷ 50	RB09Z	2121
	3	50 ÷ 130	2	90 ÷ 210	3	25 ÷ 70	1	15 ÷ 50	RB09Z	3231
	4	110 ÷ 200	3	180 ÷ 350	4	70 ÷ 110	2	20 ÷ 100	RB09Z	4342
	5	200 ÷ 350*	4	300 ÷ 600	4	70 ÷ 110	X	-	RB09Z	544X
	6	300 ÷ 500*	5	500 ÷ 900*	5	180 ÷ 300*	X	-	RB09Z	655X
DN 100	1	13 ÷ 22	1	40 ÷ 110	1	7 ÷ 15	1	15 ÷ 50	RB10Z	1111
	2	20 ÷ 55	1	40 ÷ 110	2	15 ÷ 25	1	15 ÷ 50	RB10Z	2121
	3	45 ÷ 120	2	90 ÷ 210	3	25 ÷ 70	1	15 ÷ 50	RB10Z	3231
	4	110 ÷ 200	3	180 ÷ 350	4	70 ÷ 110	2	20 ÷ 100	RB10Z	4342
	5	200 ÷ 350*	4	300 ÷ 600	4	70 ÷ 110	X	-	RB10Z	544X
	6	300 ÷ 500*	5	500 ÷ 900*	5	180 ÷ 300*	X	-	RB10Z	655X

* = versioni con membrana rinforzata. Le tarature contrassegnate con * non sono intercambiabili con le versioni standard (quelle senza *).

* = versions with reinforced diaphragm. Settings marked with * are not interchangeable with standard settings (the one without *).

* = versions avec membrane renforcée. Les étalonnages marqués avec * ne sont pas interchangeables avec les versions standards (ceux sans *).

* = versiones con membrana reforzada. Las calibraciones marcadas con * no son intercambiables con las versiones estándar (sin *).

In tabella sono indicati i codici delle versioni più comuni e con sfioro e UPSO incorporati.
Per altre combinazioni vedere indicazioni a pag. 57.

The table shows the codes of the more common versions with built-in relief valve and UPSO.
For other combinations see the instructions on page 57.

Dans le tableau sont indiqués les codes des versions les plus courantes avec évacuation et UPSO incorporés.
Pour d'autres combinaisons, voir les indications aux pages 57.

En la tabla se indican los códigos de las versiones más conocidas y con alivio y UPSO incorporados.
Para otras combinaciones, consulte las indicaciones de las páginas 57.

Ci riserviamo qualsiasi modifica tecnica e costruttiva.
We reserve the right to any technical and construction changes.
Nous nous réservons le droit de toute modification technique et constructive.
Nos reservamos el derecho de realizar cualquier cambio técnico y estructural.

The logo for MADAS features the word "MADAS" in a bold, red, italicized sans-serif font. The text is centered within a blue horizontal bar. Above and below the letters "M" and "S" are thick black horizontal bars that extend slightly beyond the width of the letters, creating a stylized, industrial appearance.